



# Pure-Flo<sup>®</sup> & EnviZion<sup>®</sup> High Purity Diaphragm Valves

Product Selection Guide



**ITT**

# Table of Contents

Introduction - Section A

Diaphragm Valve Bodies - Section B

Integrated Block Valves - Section C

Diaphragms - Section D

Topworks - Section E

Automation and Controls - Section F

General Engineering - Section G

Sample and Bleed Valves - Section H

Diaphragm Valves



These symbols are used throughout this catalog to indicate information that is applicable to either the standard Pure-Flo valve or the EnviZion valve.



Standard Pure-Flo



EnviZion

## Global presence ... local feel

World class manufacturing facilities and engineering resources located throughout the world allows Pure-Flo to support customers with local expertise backed up by the strength and reliability of a global corporation. Manufacturing locations are located in Lancaster, Pennsylvania, Obernkirchen, Germany, and Mumbai, India. Please contact us for more information about our manufacturing locations.

## Partnership for success

Consistently atop the Forbes lists for best run companies, ITT is a strong, ethical company with visions and values that reflect those of our customers and our employees. By forming partnerships with our customers based on respect, responsibility and integrity your success will be our success.



Engineered Valves, LLC  
Lancaster, Pennsylvania



ITT Bornemann GmbH  
Obernkirchen, Germany



Tecnik Fluid Controls Pvt. Ltd.  
Mumbai, India

# Standard Pure-Flo<sup>®</sup> & EnviZion<sup>®</sup> Valves

## P Standard Pure-Flo Valve

The Pure-Flo valve has earned a reputation for innovation, quality and performance. Providing products from standard forged valves to the most innovative block technology, each and every Pure-Flo valve is engineered to the highest standards. ITT Pure-Flo offers high quality hygienic valves and process components. Through both standard and custom valve assemblies, ITT is committed to helping the industry operate more effectively, efficiently and safely.

## E EnviZion Valve

ITT's breakthrough technology, the EnviZion valve, sets a new standard for the future of hygienic diaphragm valves. The EnviZion valve is designed specifically to help customers install, operate, and maintain their valves more efficiently. This unique design provides a significant reduction in total cost of ownership while supporting the industries' goals to increase productivity, improve reliability and enhance cleanability.

	Pure-Flo	EnviZion
Size Range	.25-4" (DN 6-100)	.25-2" (DN 6-50)
Valve Body	Forged, Cast, Wrought	Forged, Wrought
Surface Finish	10 – 25 Ra (.25µm - 0.6 µm) Interior & exterior Electropolish available	10 – 25 Ra (.25µm - 0.6 µm) Interior & exterior Electropolish available
Diaphragms	E1, TME, B, P, W1	TMZ
Topworks	Manual and Pneumatic	Manual and Pneumatic
Standard Features	<ul style="list-style-type: none"> <li>Working parts are isolated from process fluids</li> <li>Top entry design allows for in-line maintenance</li> <li>Diaphragm and weir assures positive closure</li> <li>Hygienic design complies to industry standards (FDA, USDA, ASME BPE, USP)</li> <li>Resists alcohol and most caustic washdowns</li> </ul>	Pure-Flo features plus: <ul style="list-style-type: none"> <li>Fasteners eliminated, no tools required</li> <li>Thermal compensation system provides an active 360° seal</li> <li>Quick change bonnet</li> <li>Safety lock-pin</li> <li>No loss of seal integrity during thermal cycling</li> </ul>



# Pure-Flo<sup>®</sup> Valve

The Pure-Flo brand is synonymous with the highest quality, precision engineered hygienic diaphragm valves. Pure-Flo valves offers superior hygienic processing components for the global hygienic processing industries (Pharmaceutical, Bioprocessing and Fine Chemical). Through both standard and custom designed valve assemblies, ITT Pure-Flo is committed to providing the best quality and value in engineered solutions for your unique flow-control needs.

The Pure-Flo valve product line began in 1978 as an extension to the venerable Dia-Flo product line. Since then ITT has been delivering to the Biopharm industry a reliable and process proven stainless steel hygienic diaphragm valve.



## Process Proven Hygienic Diaphragm Valve

Providing products from standard forged valves to the most innovative block technology, each and every Pure-Flo valve is engineered to the highest standards.

- Bonnet isolation: The diaphragm isolates the working parts of the valve from process fluids.
- Streamlined fluid passage: The smooth contoured body, streamlined flow path, and high quality interior surface prevents accumulation of process fluids or contaminants.
- Minimal contact surface: The process contact surfaces (i.e. body and diaphragm) are minimal, enhancing the ease of cleaning and sterilization.
- Positive closure: The resilient diaphragm bead in contact with the metal weir assures positive closure.
- Ideal for CIP and SIP: Clean in place and steam in place operations may be performed in line without valve disassembly or operation.
- In-line maintenance: The top entry design allows for in-line maintenance.



# EnviZion<sup>®</sup> Valve

## Experience the Future with EnviZion

The Biopharm industry relies on hygienic diaphragm valves for demanding process applications due to their unique balance of clean-ability, drain-ability and pressure/temperature capability. For more than 40 years the technology of these valves has changed very little. Advances in performance have been nominal as the basic design concept has remained the same: body, diaphragm, topworks, and four fasteners. This design requires experienced personnel and stringent maintenance practices to assure consistent, reliable valve performance. All while the industry is forced to increase productivity, extend preventative maintenance intervals, and reduce operating costs.

The EnviZion valve utilizes a breakthrough mount and turn design that allows for quick and easy valve disassembly.

- Tool-less maintenance - no tools required for valve installation and diaphragm replacement, simplifying the maintenance process.
- Fasteners eliminated - no more handling loose parts or accessing fasteners in tight spaces.
- Save time - diaphragm changes reduced from an industry average of 23 minutes to 3 minutes, resulting in a 90% reduction in maintenance time.



Introduction

## Reliable Sealing and Improved Cleanability with No Re-Torques

The EnviZion valve eliminates the effects of thermal cycling with an integrated thermal compensation system.

- Active sealing technology - the constant force of the thermal compensation system provides a reliable seal that does not degrade over time (unlike other diaphragm valve designs that use passive sealing technology).
- No retorquing - the seal is maintained over varying operating conditions, eliminating the need to adjust fasteners after thermal cycling.

The EnviZion valve improves clean-ability by reducing the potential for fluid entrapment.



- Diaphragm seal - the valve body and diaphragm create a seal on the leading edge of the D-section, preventing fluid from getting into areas which would be difficult to clean and possibly lead to process contamination.

**Net result - reduced maintenance hours, commissioning costs and potential for system contamination.**

# Product Details

## Diaphragm Valve Bodies

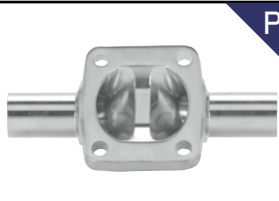
Introduction

				
Type	Forged (2-Way)	Forged (2-Way)	Wrought <sup>2</sup> (Block Bodies)	Cast
Size Range	0.25-4 in. DN6-100	0.25-2 in. DN6-50	0.25-4 in. DN6-DN100	0.5-4 in. DN15-100
End Connections	<ul style="list-style-type: none"> <li>Hygienic clamp ends</li> <li>14, 16, 18, 20 O.D. Gauge Tubing</li> <li>ISO Ends</li> <li>SMS 1146 Ends</li> <li>DIN 11850 Ends</li> </ul>	<ul style="list-style-type: none"> <li>Hygienic clamp ends</li> <li>14, 16, 18, 20 O.D. Gauge Tubing</li> <li>SMS 1146 Ends</li> <li>DIN 11850 Ends</li> </ul>	<ul style="list-style-type: none"> <li>Hygienic clamp ends</li> <li>14, 16, 18, 20 O.D. Gauge Tubing</li> <li>Schedule 5, 10, 40 Piping</li> <li>ISO Ends</li> <li>SMS 1146 Ends</li> <li>DIN 11850 Ends</li> </ul>	<ul style="list-style-type: none"> <li>Hygienic clamp ends</li> <li>14, 16, 18, 20 O.D. Gauge Tubing</li> <li>Schedule 5, 10, 40 Piping</li> <li>ISO Ends</li> <li>DIN 11850 Ends</li> </ul>
Material	316L Stainless Alloy Tri Certified to ASTM A182 Grade 316L,S9, EN 10222-5 EN 1.4435, BN2	316L Stainless Alloy Tri Certified to ASTM A182 Grade 316L,S9, EN 10222-5 EN 1.4435, BN2	316L Stainless Alloy ASTM A479, A240, A276, 316L	316L Stainless Alloy ASTM A351 Grade CF 3M
Special Alloys <sup>1</sup>			C22, C276, AL6XN	
Dimensional Standards	USOD Tubing, ISO/DIN/SMS	USOD Tubing, DIN/SMS	USOD Tubing, Pipe, ISO/DIN	USOD Tubing, Pipe, ISO/DIN







1 Other materials available upon request

2 Standard on tank bottom valves, divert valves and any block bodied fabrications.

# Product Details

## Diaphragms

Introduction

	 P	 P	 P	 P	 P	 E
Type	B	P	W1	E1	TME	TMZ
Material	Black Butyl Rubber	Buna N	White Butyl Rubber	EPDM <sup>1</sup>	PTFE Enhanced Backing	PTFE Enhanced Backing
Size Range						
0.25" (DN6)				•	•	
0.375" (DN10)				•	•	
0.5" (DN15)	•	•	•	•	•	•
0.75" (DN20)	•	•	•	•	•	•
1" (DN25)	•	•	•	•	•	•
1.5 (DN32/40)	•	•	•	•	•	•
2" (DN50)	•	•	•	•	•	•
2.5" (DN65)	•	•	•	•	•	
3" (DN80)	•	•	•	•	•	
4" (DN100)	•	•	•	•	•	
Temperature	-20–250°F -29–121°C	10–180°F -12–82°C	0–225°F -18–107°C	-22–302°F <sup>2</sup> -30–150°C <sup>2</sup>	-4–329°F -20–165°C	-4–329°F -20–165°C
Compliance	FDA USDA	FDA USDA	FDA USDA	FDA USP	FDA USP	FDA USP

<sup>1</sup> For high temperature and/or high cycle applications, contact ITT.

<sup>2</sup> Temperature range is as follows:

-4–194°F (-20–90°C) for liquid applications

-22–285°F (-30–140°C) for continuous steam

-22–302°F (-30–150°C) for intermittent steam

# Product Details

## Manually Operated Topworks

Introduction

								
Type	Bio-Pure	Bio-Pure COP	Bio-Tek	903	913	963	970	ZH,ZHS
Size Range								
0.25 (DN6)	•	•	•					
0.38 (DN10)	•	•	•					
0.5" (DN15)	•	•	•	•	•	•	•	•
0.75" (DN20)				•	•	•	•	•
1" (DN25)				•	•	•	•	•
1.5 (DN32/40)				•	•	•	•	•
2" (DN50)				•	•	•	•	•
2.5" (DN65)				•	•	•		
3" (DN80)				•	•	•		
4" (DN100)				•	•	•		
Material	Bonnet: 316 Stainless Steel Handwheel: Polyethersulfone (PES)	Bonnet: 316 Stainless Steel Handwheel: Polyethersulfone (PES)	Bonnet: 316 Stainless Steel Handwheel: Polyethersulfone (PES)	Cast Iron coated White Epoxy or PVDF	Bonnet and Handwheel: Stainless Steel	Bonnet and Handwheel: Glass reinforced polyethersulfone (PES)	Bonnet: 316 Stainless Steel Handwheel: Glass reinforced polyethersulfone (PES)	Bonnet: Stainless Steel Handwheel/ Bonnet Cover: Polyethersulfone (PES)
Maximum Service Pressure	150 psi 10.34 bar	150 psi 10.34 bar	150 psi 10.34 bar	0.5–1": 200 psig 13.8 bar 1.5–2": 175 psig 12.1 bar 3–4": 150 psig 10.3 bar	0.5–1": 200 psig 13.8 bar 1.5–2": 175 psig 12.1 bar 3–4": 150 psig 10.3 bar	150 psig 10.34 bar	0.5–1": 200 psig 13.8 bar 1.5–2": 175 psig 12.1 bar	150 psig 10.34 bar
Maximum Service Temperature	329°F (165°C)	329°F (165°C)	329°F (165°C)	See page D-9	See page D-9	300°F (149°C)	See page D-9	See page D-9
Pressure/ Temperature Limitations	See page D-9							
Autoclavable	Yes	Yes	Yes	No	Yes	Yes	Yes	Yes
Sealed Option	No	Yes	Yes	Yes	Yes	Yes	No	Yes



# Product Details

## Pneumatic Actuators

	 P	 P	 P	 P	 P	 E
Type	Advantage 2.1 Actuator	Advantage Compact Stainless	Advantage Actuator Series 33	Advantage Actuator Series 47	Dia-Flo Actuator	EnviZion Actuator
Size Range						
BP - 0.25-0.5 (DN6-15)		•				
BT - 0.25-0.5 (DN6-15)	•					
0.5" (DN15)	•	•			•	•
0.75" (DN20)	•	•			•	•
1" (DN25)	•	•			•	•
1.5 (DN32/40)	•	•			•	•
2" (DN50)	•	•			•	•
2.5" (DN65)			•	•	•	
3" (DN80)			•	•	•	
4" (DN100)			•	•	•	
Material	Bonnet: 316 Stainless Steel Actuator: Glass reinforced polyethersulfone (PES)	316 Stainless Steel	Bonnet: Nylon coated ductile iron (4 inch); Stainless Steel (3 inch); Actuator: Polyester Thermoset	Bonnet: Nylon coated ductile iron Actuator: Polyester Thermoset	Bonnet: Ductile iron Actuator: Aluminum	316 Stainless Steel
Maximum Service Pressure	150 psig 10.34 bar	150 psig 10.34 bar	150 psig 10.34 bar	150 psig 10.34 bar	See Dia-Flo Catalog	150 psig 10.34 bar
Maximum Service Temperature	300°F (149°C)	300°F (149°C)	300°F (149°C)	300°F (149°C)	See Dia-Flo Catalog	See page D-9
Autoclavable	Yes	Yes	No	No	No	Yes
Sealed Option	Yes	Yes	Yes	Yes	Yes	Yes

# Product Details

## Automation

			
Type	VSP & VSP+	73 Series Positioner	TMP-3000 Positioner
Size Range			
0.25" (DN6)	●		
0.375" (DN10)	●		
0.5" (DN15)	●		●
0.75" (DN20)	●	●	●
1" (DN25)	●	●	●
1.5 (DN32/40)	●	●	●
2" (DN50)	●	●	●
2.5" (DN65) <sup>1</sup>	VSP only	●	
3" (DN80) <sup>1</sup>	VSP only	●	
4" (DN100) <sup>1</sup>	VSP only	●	
Cover Material	Polysulfone, FDA compliant	Aluminum Brass Stainless Steel	Polycarbonate
Base Housing Material	Polyamide, FDA compliant, Stainless Steel (cover extension for >2" valves)	Aluminum Brass Stainless Steel	PPS
Temperature Rating	140°F (60°C)	150°F (65°C)	140°F (60°C)
Autoclavable	No	No	No
Electric Connection	One M20 conduit port (1/2" NPT adapter available).	N/A	M16x1.5 (with screw terminals)
Rotation	360°	No	360°
Mechanics	Proximity and Mechanical Switches	Proportioned valve control	Proportioned valve control
Approvals	FM / CSA / ATEX Zones 1, 2 / UL	N/A	

<sup>1</sup> 33 Series Actuators only

# Section B

# Diaphragm Valve Bodies

ITT Pure-Flo has developed a line of valve bodies that help address the needs of the Bioprocessing and Pharmaceutical industries for high quality, welded process systems.

By providing valve bodies with controlled sulfur 316L/1.4435 stainless steel material and weld tangents long enough to accept the most common orbital weld heads in the industry, we have eliminated two of the most common concerns in valve-to-tube welding known today.

Automatic welding of 316L process components is greatly affected by the sulfur content of the mating process components. A disparity of sulfur content can result in reduced orbital weld quality and potentially incomplete fusion of the mating components. By controlling valve body sulfur content to the same chemistry as that required for ASME BPE fittings, welding problems due to material chemistry differences will be greatly reduced.

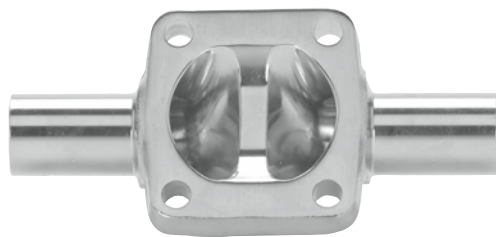

Diaphragm  
Valve Bodies

## Table of Contents

Body Dimension Charts . . . . .	B2-3
Pure-Flo Valve Bodies . . . . .	B4
Manufacturing Methods . . . . .	B5-6
Surface Finish . . . . .	B7
Electropolishing . . . . .	B8
Marking . . . . .	B9
Process Fabrications . . . . .	B10

# Body Dimension Charts

## Dimensions for Standard Pure-Flo Valve

P

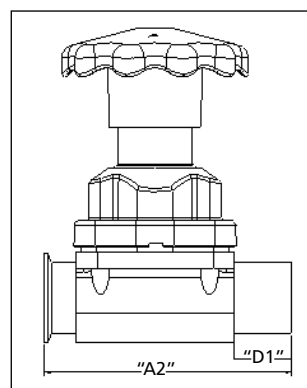
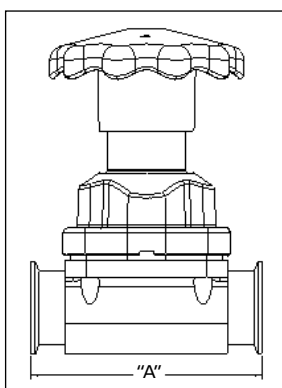
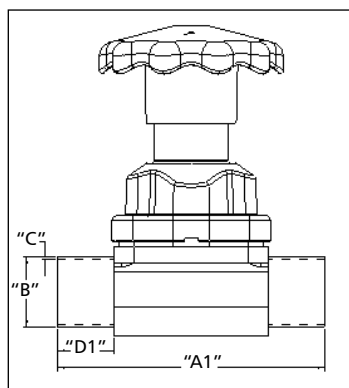

Body Dimension Charts US & SMS

USOD (ANSI) Forgings & Castings										SMS	
B		A	A1	D1	A2	C				B	C
End Connection Size		Overall Length	Overall Length	Weld Tangent	Overall Length	20 GA. 0.035"	18 GA. 0.049"	16 GA. 0.065"	14 GA. 0.083"		
IN	DN	Tri Clamp	Extended BW Forging	Extended BW Forging	TC x BW	Extended BW Forging	Extended BW Forging ASME BPE	Extended BW Forging	Extended BW Forging ASME BPE	BW Forging	
<b>Forgings</b>											
BP/BT 0.25"	DN6	2.5" (64)	3.5" (89)	1" (25)	3.0" (76,2)	S	O				
BP/BT 0.375"	DN10	2.5" (64)	3.5" (89)	1" (25)	3.0" (76,2)	S	O				
BP/BT 0.5"	DN15	2.5" (64)	3.5" (89)	1" (25)	3.0" (76,2)		O	S			
0.5"	DN15	3.5" (89)	5.06" (128)	1.5" (38)	4.28" (108,7)	O	O	S	O		
0.75"	DN20	4" (102)	5.5" (140)	1.5" (38)	4.75" (120,7)	O	O	S	O		
1"	DN25	4.5" (114)	5.93" (151)	1.5" (38)	5.22" (132,6)		O	S	O	(25)	(1,2)
1.5"	DN40	5.5" (140)	6.8" (173)	1.5" (38)	6.15" (156,2)		O	S	O	(38)	(1,2)
2"	DN50	6.25" (159)	7.42" (188)	1.5" (38)	6.84" (173,7)			S	O	(51)	(1,2)
2.5" <sup>2</sup>	DN65	8.75" (222) <sup>1</sup>	9.94" (252)	1.75" (44,5)	9.34" (237,2)			S		(63,5)	(1,6)
3"	DN80	8.75" (222)	9.94" (252)	1.75" (44,5)	9.34" (237,2)			S	O	(76,1)	(2)
4"	DN100	11.5" (292)	13" (330)	2.0" (51)	12.25" (311,2)			O	S		
<b>Castings</b>											
0.5"	DN15	3.5" (89)	N/A	N/A	3.5" (89)	O	O	S	O		
0.75"	DN20	4" (102)	N/A	N/A	4" (102)	O	O	S	O		
1"	DN25	4.5" (114)	N/A	N/A	4.5" (114)		O	S	O	(25)	(1,2)
1.5"	DN40	5.5" (140)	N/A	N/A	5.5" (140)		O	S	O	(38)	(1,2)
2"	DN50	6.25" (159)	N/A	N/A	6.25" (159)			S	O	(51)	(1,2)
2.5"	DN65	7.62" (194) <sup>1</sup>	N/A	N/A	7.62" (194)			S	O	(63,5)	(1,6)
3"	DN80	8.75" (222)	N/A	N/A	8.75" (222)			S	O	(76,1)	(2)
4"	DN100	11.5" (292)	N/A	N/A	11.5" (292)			O	S		

<sup>1</sup> For 2.5" overall length does not comply with ASME BPE dimensions

<sup>2</sup> 2.5" size uses 3" topworks

Note: Extended Weld Tangents are available only with USOD (ANSI) end connections.

Dimensions in ( ) are mm

S = Standard, O = Optional, BT = Bio-Tek Body, BP = Bio-Pure

# Body Dimension Charts

## Dimensions for Standard Pure-Flo Valve

P

### ISO/DIN Forgings

End Connection Size	Topworks Size	ISO										DIN Series 1		DIN Series 2		DIN Series 3		
		A	D1	B	C								B	C	B	C	B	C
		mm	mm	mm	1	1,2	1,6	2	2,3	2,6	2,9	mm	mm	mm	mm	mm	mm	
DN6	Bio-Tek	89 <sup>1</sup>	25 <sup>1</sup>	8	S	O						8	1					
DN10	Bio-Tek	89 <sup>1</sup>	25 <sup>1</sup>	13,5	O		S	O				10	1					
DN15	Bio-Tek	89 <sup>1</sup>	25 <sup>1</sup>	17,2	O		S	O				12	1	13	1,5	14	2	
DN15	0.5"	106	25	21,3			S	O				18	1	19	1,5	20	2	
DN20	0.75"	118	25	26,9			S	O				22	1	23	1,5	24	2	
DN25	1"	127	25	33,7			O	S				28	1	29	1,5	30	2	
DN32	1.5"	174	35	42,4			O	S				34	1	35	1,5	36	2	
DN40	1.5"	174	35	48,3			O	S				40	1	41	1,5	42	2	
DN50	2"	191	35	60,3				S	O	O	Cast Only	52	1	53	1,5	54	2	
DN65	3"	254	44.5	76,1				O	S	O		70	2					
DN80	3"	254	44.5	88,9					S	O		85	2					
DN100	4"	330	51	114,3					S	O		104	2					

<sup>1</sup> BT TC x BW and TC x TC bodies are 64 mm overall length with 13 mm tangent

Note: All measurements are mm unless otherwise noted.

S = Standard, O = Optional

Diaphragm  
Valve Bodies

## Dimensions for Standard Pure-Flo EnviZion Valve

E

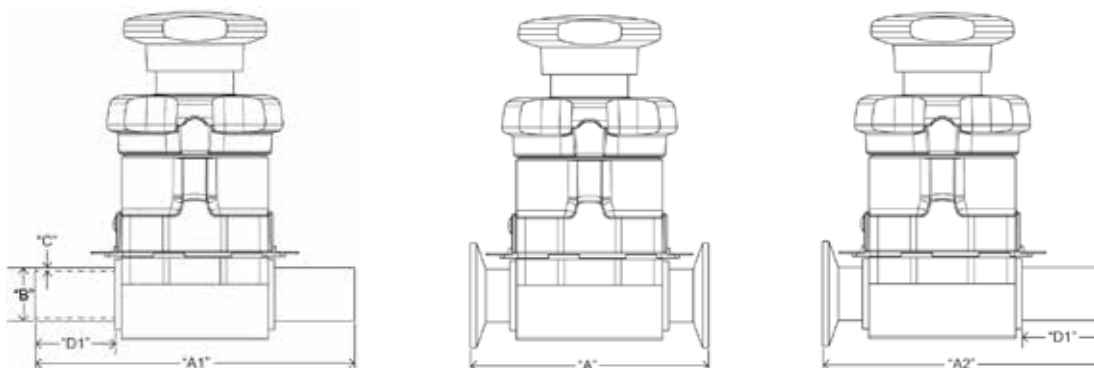

USOD (ANSI)						
B		A	A1	D1	A2	C
End Connection Size		Overall Length	Overall Length	Weld Tangent	Overall Length	16 GA.
IN	DN	Tri Clamp	Extended BW	Extended BW	TC x BW	Extended BW
Forgings						
0.5"	DN15	3.5" (89)	5.22" (133)	1.5" (38)	4.36" (111)	.065" (1,7)
0.75"	DN20	4" (102)	6.00" (152)	1.5" (38)	5.00" (127)	.065" (1,7)
0.75"R	DN20	4" (102)	6.00" (152)	1.5" (38)	5.00" (127)	.065" (1,7)
1"	DN25	4.5" (114)	6.00" (152)	1.5" (38)	5.25" (133)	.065" (1,7)
1.5"	DN40	5.5" (140)	7.08" (180)	1.5" (38)	6.29" (160)	.065" (1,7)
2"	DN50	6.25" (159)	7.14" (181)	1.5" (38)	6.70" (170)	.065" (1,7)

Dimensions in ( ) are mm

# Pure-Flo Valve Bodies

## Benefits of the new Pure-Flo Body:

- No welded tube extensions required for most welding equipment
- Less over-all valve body length compared to welded tube extensions
- Fewer welds in the process system
- Less validation paperwork due to fewer material certifications
- Higher quality field welds
- No narrow or off-set weld heads required.

All these benefits add up to lower installation costs and improved production schedules.

## End Connections

Pure-Flo Diaphragm Valve bodies are available in a variety of end connections:

- Hygienic Tri-Clamp
- 14, 16, 18, 20 O.D. Gauge Tubing
- Schedule 5, 10, 40 Piping
- ISO Ends
- SMS 1146 Ends
- DIN 11850 Ends

## Drainability

Pure-Flo diaphragm valves may be installed in vertical or horizontal lines as required. Drain marks are provided as standard on cast and forged bodies to facilitate installation and optimize drainability. One mark must be located in the vertical plane, cutting the centerline of the pipe.

The slope of process piping must be designed to provide proper pitch in order to optimize drainability. Drainability in a process system is ultimately the responsibility of the system designer end user.

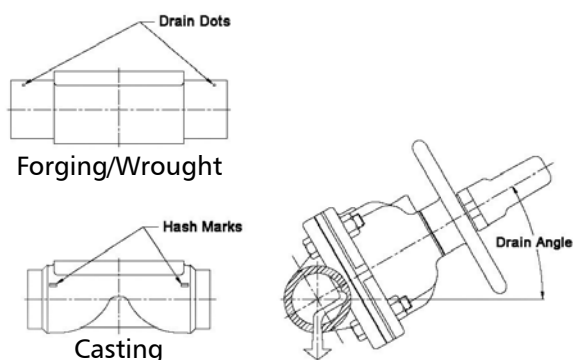

Note: Wrought bodies are machined from bar stock.

## Weld Installation

Bio-Pure, Bio-Tek, and BioviZion valves, 1/4"–1/2" (DN 6–15) and ISO End valves have minimum 1" (25 mm) cutbacks and generally do not require tube extensions for standard TIG orbital welding equipment.

Pure-Flo valves, 0.5–4" (DN15–100) have ASME BPE fitting compatible cutbacks and generally can be welded without disassembly using most standard TIG orbital welding equipment.

## Drain Angles

Valve Size		Standard Pure-Flo Forging			Standard Pure-Flo Investment Casting		EnviZion
		ANSI <sup>5</sup>	ISO	DIN	ANSI	ISO	ANSI
0.25 <sup>1</sup>	8 <sup>1</sup>	30° <sup>2</sup>	20°	20°	N/A	N/A	32°
0.375 <sup>1</sup>	10 <sup>1</sup>	30° <sup>2</sup>	20°	20°	N/A	N/A	25°
0.50 <sup>1</sup>	15 <sup>1</sup>	30° <sup>2</sup>	20°	20°	N/A	N/A	20°
0.50	15	30°	13°	16°	30°	17°	27°
0.75	20	30°	21°	25°	30°	18°	36°
0.75R	20	N/A	N/A	N/A	N/A	N/A	16°
1.00	25	30°	22°	26°	31°	20°	30°
1.25	32	N/A	22°	25°	N/A	28°	N/A
1.50	40	28°	17°	22°	30°	20°	25°
2.00	50	23°	16°	19°	25°	19°	19°
2.50	65	28° <sup>3</sup>	23°	23°	19°	N/A	N/A
3.00	80	23°	14°	18°	25°	N/A	N/A
4.00	100 <sup>4</sup>	16°	11°	14°	20°	N/A	N/A

<sup>1</sup> Bio-Pure, Bio-Tek, and BioviZion sizes.

<sup>2</sup> Bodies manufactured prior to 2010 have a 20° drain angle for the Bio-Tek butt-welded bodies with 1" (25.4 mm) cutbacks and a 30° drain angle for Bio-Tek TC bodies. Consult engineering drawings for drain angles on Bio-Tek fabrications. Bio-Pure and Bio-Tek forgings have been standardized on 30° draining angle regardless of body type.

<sup>3</sup> 3" forged body with 2.5" end connection.

<sup>4</sup> DN 100 bodies to DIN/ISO dimensions are wrought.

<sup>5</sup> Forging drain angles apply to all end connections.

Note: As a rule of thumb drain angle tolerances of +/- 2° will assure optimal drainability.

# Manufacturing Methods

## Ferrite

The selection of process components in the Pharmaceutical/Bioprocessing Industry, especially in cell culture applications, demonstrates a distinct movement toward lower ferrite materials. However, in many applications the use of higher ferrite content components may have no effect on the product, service life, or performance of the component and the inherent cost of the component is reduced. The nature of the process, utility protocols (i.e. passivation, cleaning, sterilization, fabrication), as well as additional surface preparation of the material such as electropolishing, will impact the extent of the components corrosion resistance. ITT provides customers a choice in body types based on the needs and requirements of the customers process application.

Ferrite can be defined as the ferromagnetic, body-centered, microstructural constituent of variable chemical composition in iron-chromium-nickel alloys. This may be formed upon solidification from molten metal (delta ferrite) or by transformation from austenite or sigma phase on cooling in the solid state (alpha ferrite). The formation of ferrite is therefore a natural occurrence in stainless alloy products. Ferrite levels can be determined utilizing several techniques including chemical analysis, metallographic examination and magnetic attraction. Ferrite is depleted as the material is worked, i.e. castings having the highest content and forgings having the lowest. Free delta ferrite contained in components in a process system may or may not be of concern to the end user.

## Metallurgy

ITT Pure-Flo customers have a choice of valve body types based on the needs and requirements of the process application. Pure-Flo standard body material for forged bodies is 316L, 1.4435 sulfur controlled to ASME BPE standards.

Wrought bodies are available in 316L, 1.4435 or other special materials. Biopharmaceutical applications may require special alloys or materials to provide a desired performance. Consult a Pure-Flo representative for availability and application information.

All valve bodies are fully material heat traceable to EN 10204 3.1B. Certified Mill Test Reports are provided as standard.

# Manufacturing Methods

## Forged

Pure-Flo bodies are produced from round stock or plate which has been processed from an ingot. The round stock or plate is compressed between two halves of a forging tool at elevated temperatures. The result is a shape which is then machined to create the shape required. Machining required is more extensive than a casting. Ferrite content for the ANSI Pure-Flo and ISO/DIN forged product lines is 0.5%.

## Wrought

The tank bottom valves, divert valves and block body fabrications are produced from wrought material. Wrought material is worked material such as plate or round stock. Rather than forging a shape between two halves of a tool, as in the case of a forged body, the shape required is machined directly from wrought material. Ferrite content in wrought material may vary depending primarily on the metallurgy of the material used.

Diaphragm  
Valve Bodies

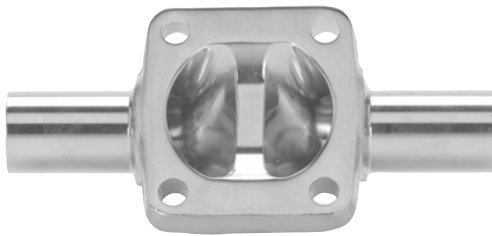

## Cast

Pure-Flo bodies are produced utilizing the lost wax or investment cast method. A wax impression is created for the shape required. The wax impression is dipped or sprayed with ceramic material and then fired in a kiln. The wax evaporates leaving behind a hard ceramic shell into which molten material is poured. The solidification of molten metal may cause sub-surface porosity, which varies in occurrence depending on casting techniques, machining and interior finish specifications. The result is a product complete with flow path, bolt holes, drain marks and body identification marks cast into the required shape. Machining is, therefore, minimal. Pure-Flo castings go through a rigorous qualification program to ensure the highest attainable quality is achieved. The levels of porosity are the absolute minimum possible. Conformance to ASME BPE surface finish requirements are not guaranteed.



# Surface Finish

Pure-Flo valve bodies are available in a complete range of mechanically polished and electropolished internal surface finishes to satisfy system design requirements. Pure-Flo valves are available in a complete range of ASME BPE compliant internal surface finishes.

ITT Pure-Flo provides a complete range of both internal and external electropolish options. Electropolish surface finishing creates a superior surface finish for biopharmaceutical applications. Electropolishing improves corrosion resistance, removes inclusions and contaminants, and improves the over-all surface for cleaning and sterilization.

## Mechanical Polish Surface Finish (Interior Only)

Code	Non-EU Service Microinch Max	EU Service Micron Max
0	No Mechanical Polish	No Mechanical Polish
2	35 Ra	0.8 Ra
6	25 Ra	0.6 Ra
8	20 Ra	0.5 Ra
7	15 Ra	0.38 Ra
9	11 Ra	0.28 Ra
10	10 Ra	0.25 Ra

## Electropolish Surface Finish (Interior & Exterior)

Code	Surface Finish
0	No Electropolish
2	Exterior Electropolish only
3	Both Interior and Exterior Electropolish
4	Interior Electropolish only

## Surface Finishes per ASME BPE

### Mechanical Polished Surface Finish (Interior Only)

Code	R <sub>a</sub> , MAX	
	μ-in	μm
SF1	20	0.51
SF2	25	0.64
SF3	30	0.76

### Mechanical Polished & Electropolished Surface Finish (Interior Only)

Code	R <sub>a</sub> , MAX	
	μ-in	μm
SF4	15	0.38
SF5	20	0.51
SF6	25	0.64

#### General Notes:

1. All Ra readings are taken across the lay, wherever possible.
2. No single Ra reading shall exceed the Ra max. value in this table.
3. Other Ra readings are available if agreed upon between owner/user and manufacturer, not to exceed values in this table.

# Electropolishing

Electropolishing is the electrochemical method of removing metal from a surface. Formally, electropolishing is defined as anodic dissolution in the presence of an electrolyte and an imposed current potential.

The inherent benefits derived from electropolishing are as follows:

- Provides a continuous, tenacious, chromium-rich oxide layer on the surface resulting in an excellent passive film enhancing corrosion resistance
- Surface leveling reduces the total surface height and relieves much of the surface tension inherent in mechanical polishing
- Enhances the optimization of cleanability and sterilization

- Provides a quality control mechanism exposing surface pits and defective welds
- Exposes and removes impurities within the surface layer
- Provides a lustrous, aesthetically pleasing appearance

For the reasons mentioned, the use of electropolishing over a mechanically polished surface is becoming more prevalent on the surfaces of system components in critical pharmaceutical and bioprocessing applications. The Pure-Flo product line is available with electropolished interior and exterior surfaces, sizes 0.25–4" (DN 6–100).

Diagram of a Typical Electropolishing Cell

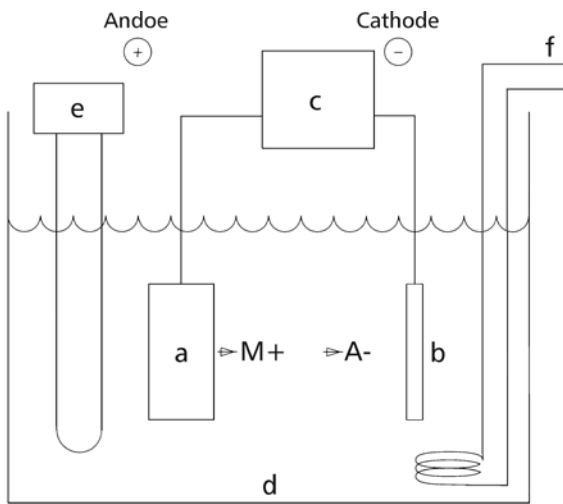

Legend

- a Anode
- b Cathode
- c Power Source
- d Electrolyte
- e Heater and Temperature Regulator
- f Cooling Coil
- M+ Metal Ion
- A- Anion

Diagram Illustrating Micropolishing and Macropolishing

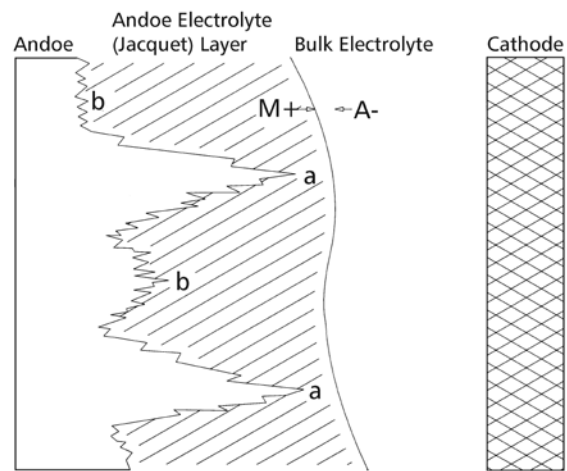

Legend

- a Region of Macropolishing
- b Region of Micropolishing
- M+ Metal Ion
- A- Anion

# Marking

Pure-Flo valve bodies are marked directly on the valve body, typically on the bottom of the valve or underside of the bonnet flange. Additional information such as customer tag number is available upon request.

## Validation

ITT provides critical validation information to meet the needs of the Pharmaceutical and Bioprocessing industries.

## Certified Mill Tests Reports

All Pure-Flo Valve bodies contain a permanently etched heat number traceable per EN 10204 3.1. Certified Mill Test Reports (CMTRS) are provided as standard on all Pure-Flo valves.

## Certificate of Compliance to Specifications

A Certificate of Compliance to customer specification is provided as a standard on all Pure-Flo valves.

- Certification of compliance to CFR Title #21 section 177
- Certification to USP Class VI compliance and/or physical testing document

Additional Validation information available on request

- Interior Surface Characterization documentation
- Quality assurance manual
- ISO 9001 certification
- Certification of testing to MSS-SP-88

Certificate and document packages can be downloaded from [www.engvalves.com](http://www.engvalves.com)

## Standard Marking (New Generation)

HC  
S-N 300002567  
1-316L-RA25MAX-SF2-CWP-150  
XV109











## European Union Service Valve Marking

HC  
S-N 6677002-001-001  
DN25-316L-RA0.5MAX-PN16  
Group 1 GAS TEST 16 BARG  
XV109

## Standard Marking (India)

HC  
S-N 1700001-10-1  
DN25-316L-RA0.5MAX-PN16  
XV109

Legend:

 Heat Code	 Material	 PED Class (EU only)
 Serial Number	 Max Surface Finish	 Test Pressure (EU only)
 Size	 Cold Working Pressure	 Customer Tag# (optional)
 Order Number		

# Process Fabrications

Process fabrications consist of multiple 2-way valves ported in various ways to fit the application. The intent is to reduce hold up volume and improve drainability versus using standard valves and fittings. Process fabrications minimize the distance between valves improving cleanability and reducing risk of contamination. Fabrications are utilized when hold up volumes are a consideration but not critical. Many process fabrication combinations can comply with the cGMP requirements.

There are three styles of standard two valve fabrications:

## GMP Option:

The GMP fabrication is typically oriented in the vertical position. The design is utilized to reduce dead legs on point-of-use outlets in a typical WFI distribution loop.

## Sterile Access Option:

The Sterile Access orientation is designed for use when the orientation of the main valve is horizontal and the secondary or purge valve or outlet is in the vertical position. The main valve is ported at the low point of the main valve waterway to achieve optimum drainability when the main valve is on its drain angle.

## Horizontal Sterile Access Option:

The Horizontal Sterile Access orientation is similar in configuration to the Sterile Access configuration, but is employed when both the main valve and secondary valve have horizontal orientation.

## Typical Applications:

Sampling, steam condensate drain, divert port, and block and bleed.

## Size Range

0.25–4" (DN6–100) main valve  
0.25–4" (DN6–100) purge valve

## Body Material

316L Stainless Steel Forging, ASTM A-182 (Standard on EnviZion 0.5-1.5" main valve; Standard on Pure-Flo 4")

316L Stainless Steel Wrought, ASTM A479 (Standard for main valve Bio-Pure and Bio-Tek up to Pure-Flo 3")

Other materials available upon request

## End Connections

Buttweld:

- 14, 16, 18, 20 Gauge O.D. Tubing
- Schedule 5, 10, and 40 Pipe
- DIN/ISO Ends

Hygienic clamp ends:



Note: Available in standard Pure-Flo and Pure-Flo EnviZion bodies. Body types can be the same or different.

The Pure-Flo IBV - Integrated Block Valve product line is available in standard Pure-Flo and EnviZion body types. The valves are constantly changing to meet the rigorous demands of the Biopharmaceutical processing industry. An extensive array of innovative integrated block valves specifically designed to achieve the utmost in process efficiency. Pure-Flo developed the first integrated block body diaphragm valves over 30 years ago. We have a history of listening to customers and industry needs to develop valve solutions for the toughest applications.

Biopharm processes are complex and sensitive to system and environmental factors. Drug purity and process yield is greatly affected by system design. Integrated block valves can play a substantial role in developing a robust high yield process. Many valve solutions can produce acceptable results, but Pure-Flo integrated block valve technology can make a marginal process better and a good process great.

Integrated block technology is a cost effective means of reducing total cost of ownership. By optimizing drainability, hold-up volume, deadlegs and cleanability, block technology can decrease cleaning cycle times and increase process efficiency. Combining multiple valves into a single valve body can substantially reduce total installation and validation costs. Efficient designs pay for themselves over and over again.

Utilizing powerful 3D modeling software we can create almost any valve configuration imaginable. Working hand in hand our engineers will develop the valve configuration that fit your needs to a "T".

## Table of Contents

Block Valve Benefits . . . . .	C2-3
6D Rule vs. ASME BPD L/D . . . . .	C4
P&ID Cross Reference . . . . .	C5-6
Zero Static Use Points. . . . .	C7-11
Divert & Sterile Access Valves . . . . .	C12-17
Vessel Valves . . . . .	C18-20

## Integrated Block Valves in a Typical Bioreactor Process

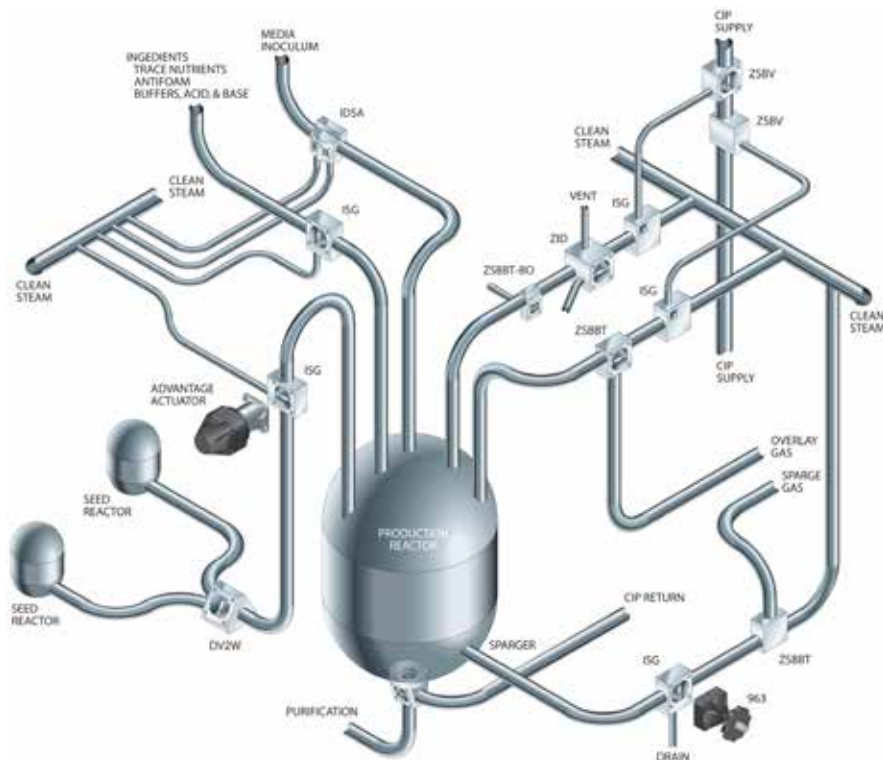

# Block Valve Benefits

## Drainability and Hold Up Volume

ITT Pure-Flo hygienic weir style diaphragm valves have become the most important control element of process piping systems utilized in the Pharmaceutical and Bioprocessing industries. The weir style diaphragm valve has become the standard due to its unique ability to provide maximum drainability and minimized product hold up volumes.

Integral Block technology further improves drainability and minimizes hold up volumes by reducing the process pipe volume between control elements.

Utilizing the unique characteristics of the weir style diaphragm valve, valve manufacturers have helped develop many process fabrications that have reduced product contact surfaces, reduced hold up volumes, and minimized piping dead-legs. The theory is that as contact surfaces are minimized, and hold-up volume are reduced in a process piping system, product yields and product purity will be improved.

## Deadlegs

The FDA Guidelines for High Purity Water Systems has "defined dead legs as not having an unused portion greater in length than six diameters of the unused pipe, measured from the axis of the pipe in use. It should be pointed out that this was developed for hot (75-80° C) circulating systems. With colder systems (68-75° C) any drop or unused portion of any length of piping should be eliminated if possible, or have special sanitizing procedures".

In the not so distant past, typical process fabrications were produced by welding of standard forged valve bodies in configurations designed specifically for certain applications and orientations. This fabrication has served the industry well, but has limitations. In many instances the dead leg between the two can fall outside FDA expectations.

4-Way Divert Valve vs. Conventional Divert Valve Assembly

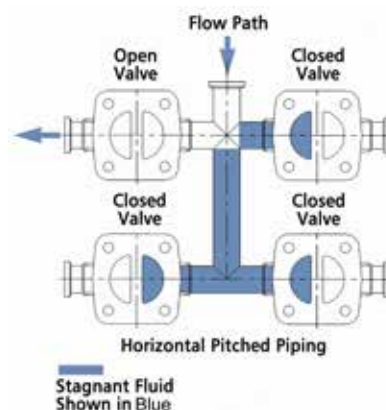
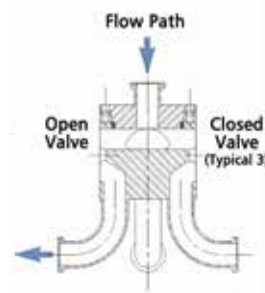

In case where process piping falls outside of FDA expectations, as noted from the High Purity Water Guide reference above, the owner of the system is expected to have special sanitizing procedures. These special sanitizing procedures can be costly in production time and processing cost and should be avoided whenever possible.

# Block Valve Benefits

## Current Good Manufacturing Practice (cGMP)

The cGMP regulation is a total quality concept applicable to processes and associated operations that assure the desired quality product. cGMP compliance, like quality, is fundamental and must be designed and built in from the earliest stages of a drug production project.

Drug manufacturers are required to maintain current Good Manufacturing Practices. This means that manufacturers must stay current with:

- New Technology
- New Methodology
- New Thinking
- New Requirements
- New Trends

One of the most critical factors in the production of drugs is the ability to clean and validate the drug production process. cGMPs require that processing equipment be designed to be cleaned and sterilized to minimize the potential for contamination, assuring the purity of the end drug product.

Hygienic weir style diaphragm valves have become the most important control element of process piping systems utilized in the Pharmaceutical and Bioprocessing industries, due to their unique ability to provide drainability with minimized product entrapment areas. Integrated block valve designs take these characteristics to an even higher level.

## Block Valves: Total Cost of Ownership

Total cost of ownership for a process system can not be calculated by material costs alone. Installation and ongoing operational costs should be taken into account when making any component purchasing decision. In many cases the cost of integrated block valves are greatly offset by reductions in installation costs, space requirements and improvements in operational efficiency.

Integrated Block Valves can improve production efficiencies by:

- Minimizing internal valve volume
- Minimizing hold up
- Minimizing dead-legs
- Reducing CIP cycle times
- Increasing product purity
- Reducing qualification and validation efforts

Integrated Block Valves also reduce:

- Installation time and cost
- Expensive field welds
- Process piping footprint



# 6D Rule vs. ASME BPE L/D

## Dead-legs - What ever happened to 6D?

Basically, a “dead-leg” is defined as a one-way water system. Dead-legs result in process systems that are difficult to clean. The FDA reference document “Guide to Inspections of High Purity Water Systems” indicates that dead-legs for hot (75-80° C) circulating water systems (self sanitizing) shall be no greater than 6 diameters of the unused pipe, measured from the axis of the pipe in use. Colder water systems (65-75° C) are not self sanitizing and therefore should eliminate dead-legs, if possible, or have special sanitizing procedures in place.

This 6D requirement has been the basic standard for many years when designing high purity water systems. Due to the method of measurement however, 6D as defined was not truly representative of what dead-leg characteristics are critical to designing a cleanable process piping system. Defining a dead-leg from the axis of the main pipe simply does not address the characteristics that affect the ability to clean and sanitize the dead-leg in question.

## ASME BPE L/D = 2:1

The Bioprocessing industry has found that 6D piping standards are not sufficient to assure optimal clean-able and sterilizable process systems. The sensitive nature of the production processes and the substantial value of the end product have required the industry to develop even more stringent requirements in critical systems. In 1997 the American Society of Mechanical Engineers (ASME) addressed this need by creating the ASME Bioprocessing Equipment Standard. The ASME BPE standard suggests that high purity water, clean steam systems and bioprocessing systems such as fermentation, purification and filtration systems can be designed to meet an L/D ratio of 2:1. L is defined as the Length of the dead-leg extension measured from the ID wall normal to the flow pattern. D is the nominal size dimension of the extension of a valve or instrument.

The ASME BPE standard states that the L/D ratio of 2:1 should be considered a target, not an absolute requirement, but the system designer/manufacturer should make every attempt to eliminate system dead-legs, and identify where exceptions exist.

Since the L/D ratio of 2:1 is a target, the system designer must make the determination of what L/D ratio is warranted for a particular system or project. In many cases L/D ratios of 2:1, 3:1 or sometimes 4:1 are utilized.

6D Rule

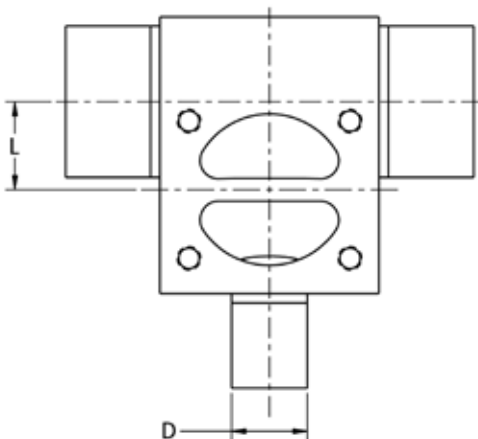

L/D = 2:1 Rule

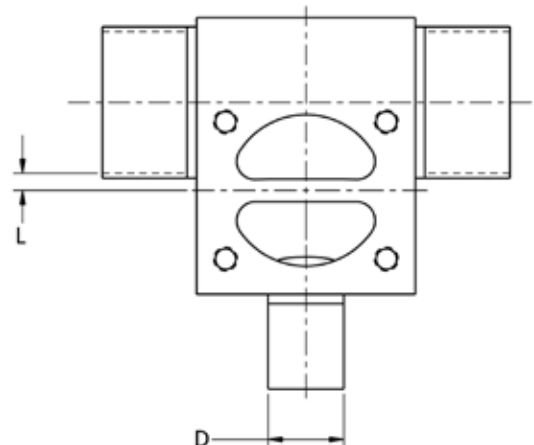

# P&ID Cross Reference

## Zero Static Use Points

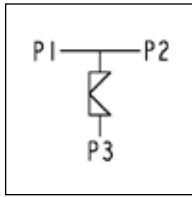

Zero Static Block Body  
Code: ZSBT

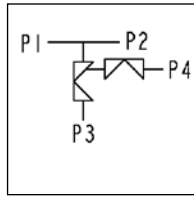

Zero Static Back to Back Sample  
Code: ZSBBS

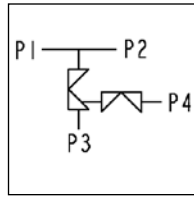

Zero Static with Downstream Purge  
Code: ZDPT, ZDPB

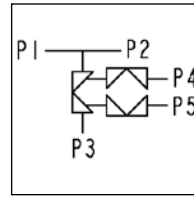

Zero Static with Upstream Sample and Downstream Purge  
Code: ZUD

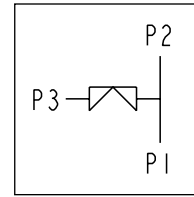

Zero Static Block Body with Vertical Run  
Code: ZSBV

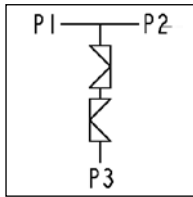

Zero Static Dual Inline  
Code: ZDI

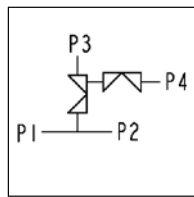

Zero Static Inverted with Drain (ZID)

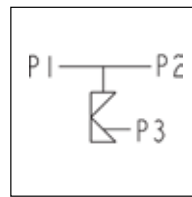

Zero Static Block Body with Back Outlet Option (ZSBT-BO)

## Divert and Sterile Access Valves

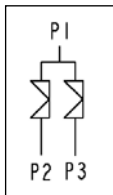

2-Way Divert Valve  
Code: DV2W

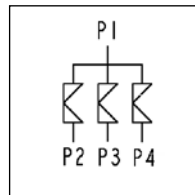

3-Way Divert Valve  
Code: DV3W

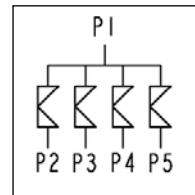

4-Way Divert Valve  
Code: DV4W

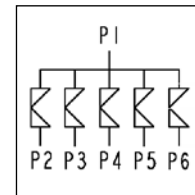

5-Way Divert Valve  
Code: DV5W

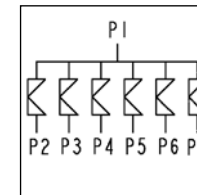

6-Way Divert Valve  
Code: DV6W

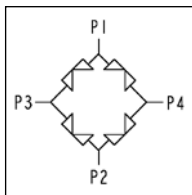

Chromatography without Bypass  
Code: CHN

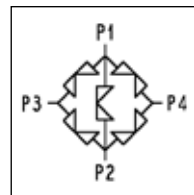

Chromatography with Bypass  
Code: CHRO

# P&ID Cross Reference

## Divert and Sterile Access Valves (cont.)

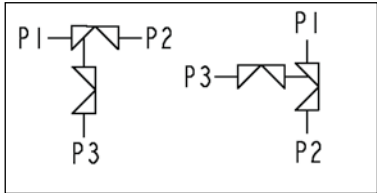

Integral Sterile Access and GMP  
Code: ISG

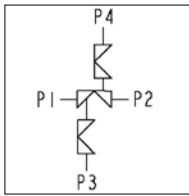

Integrated Dual Sterile Access  
Code: IDSA

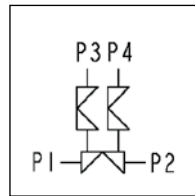

Integrated Dual Sterile Access  
Code: IDSA

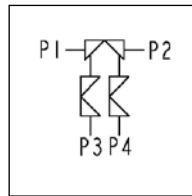

Integrated Dual Sterile Access  
Code: IDSA

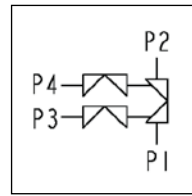

Integrated Dual Sterile Access  
Code: IDSA

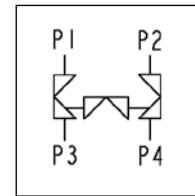

Crossover  
Code: CRO/CROD

## Vessel Valves

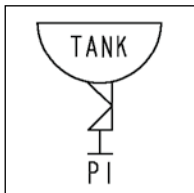

Tank Bottom Valve  
Code: TBV

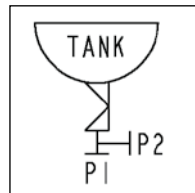

Tank Bottom Valve with CIP/SIP Port  
Code: TBV

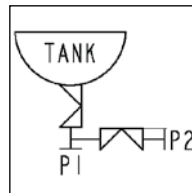

Tank Bottom Valve with CIP/SIP Valve  
Code: TBV

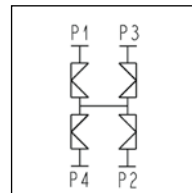

Sterile Barrier  
Code: SB1

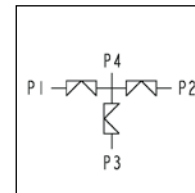

Block & Bleed with Vent Port  
Code: BBD-VP

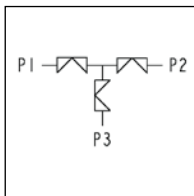

Block & Bleed  
Code: BBD

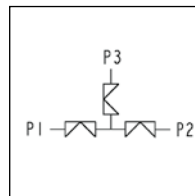

Block & Bleed  
Code: BBV

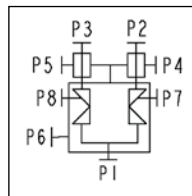

Sterile Filter Shunt Valve  
Code: DV2WS

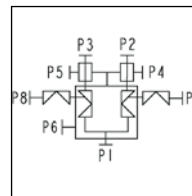

Sterile Filter Shunt Valve with Condensate Drain Valves  
Code: DV2WS

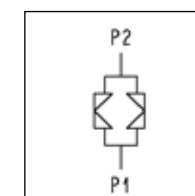

Dual Flow  
Code: DF

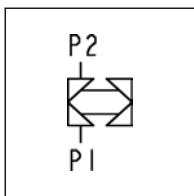

Bypass  
Code: BYP

# Zero Static Use Points

## Zero Static Tee (ZSBT)

Zero Static use points are some of the most critical valves utilized in the Biopharmaceutical industry. Use point valves allow process fluids to be transferred, sampled, drained or diverted with minimal impact on critical systems such as WFI and purified water.

Zero static Tees are some of the most critical valves utilized in the Biopharmaceutical Industry. They substantially reduce dead legs and minimize the potential for contamination.

Typical Applications:

- Point-of-use valves
- Piping Branch valves



Flow Path

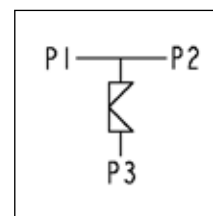

## Zero Static U-Bend (ZSBBVV, ZSBBHV, EZSBVV, EZSBHV)

Zero Static use points are some of the most critical valves utilized in the Biopharmaceutical industry. Use point valves allow process fluids to be transferred, sampled, drained or diverted with minimal impact on critical systems such as WFI and purified water.

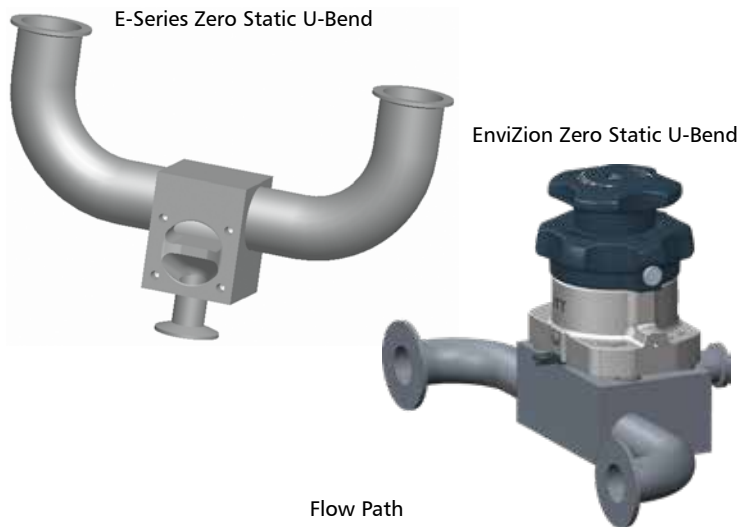

E-Series Zero Static U-Bend

EnviZion Zero Static U-Bend

Flow Path

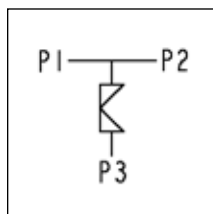

The E-Series zero static u-bend maintains the essential functional characteristics of the original zero static valve design while improving the cost effectiveness of block body assemblies. The design also utilizes ASME autoweld elbow fittings, resulting in an increased u-bend centerline dimension as compared to the original zero static valve design. All elbow welds are left in the as-welded condition. Outlet fitting welds are polished to valve surface finish requirements.

Typical Applications:

- Point-of-use valves
- Piping branch valves

# Zero Static Use Points

## Zero Static Back to Back Sample (ZSBBS)

The ZSBBS process fabrication is a modification of a standard Zero Static Tee. An integral valve located on the back of the valve assembly provides access to a sample port upstream of the Zero Static Tee weir. This sample port is utilized to take samples of the main process flow. The sample valve typically utilizes a .5" Bio-Tek or Pure-Flo valve.

The integral sample valve greatly reduces contact surfaces, hold up volume and possible deadlegs as compared to sample valves that are welded to the exterior of a standard Zero Static valve. The ZSBBS is an essential element of piping systems required to meet demanding L/D ratios suggested by the ASME BPE standard.

Typical Applications:

- Use point where sampling of loop water is required prior to opening main valve.

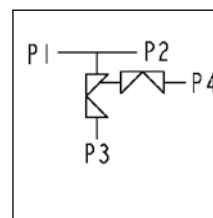

Flow Path



## Zero Static Downstream Purge (ZDPT/ZDPB)

The ZDPT and ZDPB process fabrication is a modification of a standard Zero Static valve. An integral valve located on the back of the valve assembly provides access to a purge port downstream of the main weir. This purge can be utilized for a multitude of process and utility applications including steam, CIP solution or as a gas purge. The down stream integral purge valve typically utilizes a .5" Pure-Flo valve bonnet assembly. The integral purge valve greatly reduces contact surfaces, hold up volume and possible deadlegs as compared to purge valves that are welded to the exterior of a standard zero static valve. The ZDPT and ZDPB are an essential element of piping systems required to meet demanding L/D ratios suggested by the ASME BPE standard.

Typical Applications:

- Use point applications where cleaning (CIP), steam sterilization, and blow down of the downstream is required.

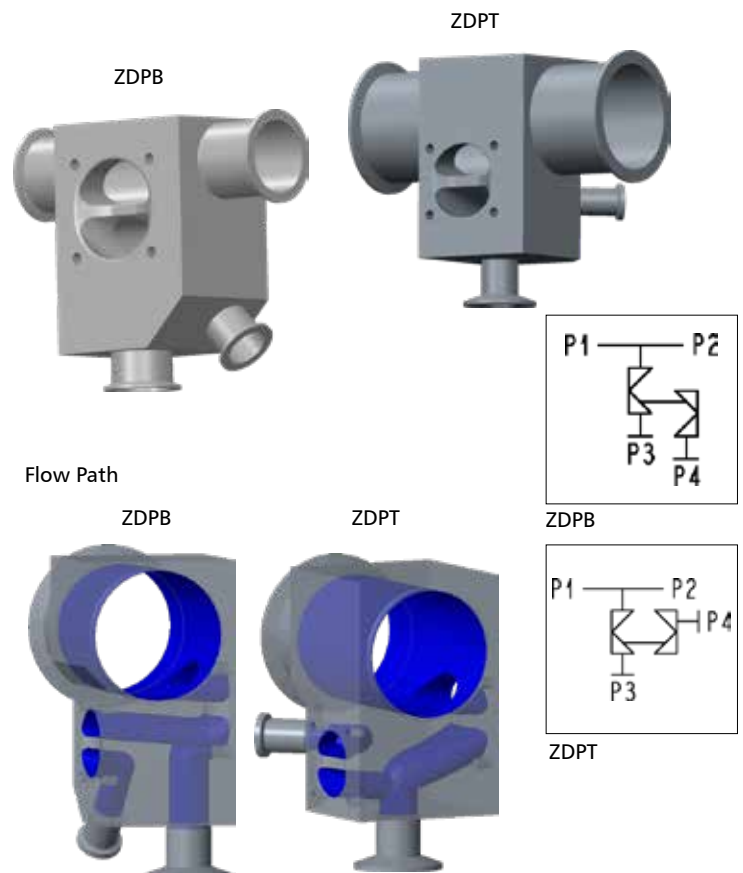

# Zero Static Use Points

## Zero Static with Upstream Sample and Downstream Purge (ZUD)

The Zero Static Upstream Sample and Downstream Purge valve allows for point of use sampling of the upstream flow, purging and sterilization of the downstream process, and sampling from the same Zero Static valve.

Typical Applications:

- A single use point with multiple outlets for purging and steam sterilization of the downstream line and sampling of the upstream line

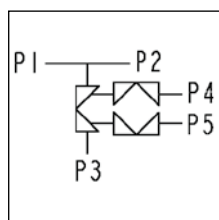
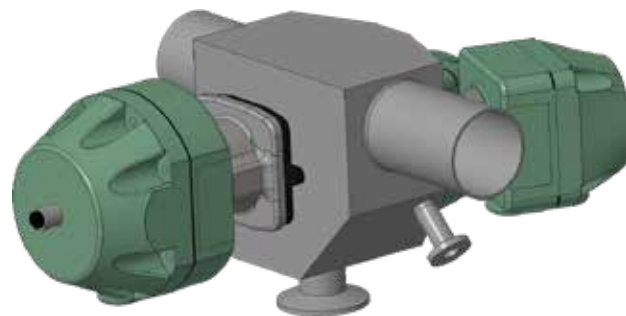

Flow Path

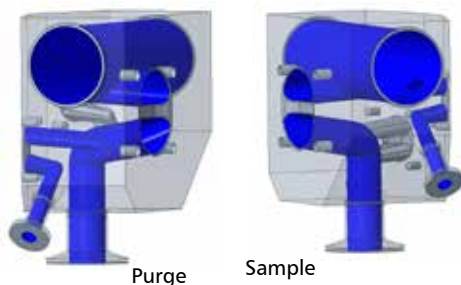

Integrated Block Valves

## Zero Static Block Body with Vertical Run (ZSBV)

Zero Static use points are some of the most critical valves utilized in the Biopharmaceutical industry. Use point valves allow process fluids to be transferred, sampled, drained or diverted with minimal impact on critical systems such as WFI and purified water.

Standard Zero Static valves are limited to horizontal main runs by vertical outlet orientations. The ZSBV greatly expands the use of the Zero Static valve by allowing optimal drainability and hold up volumes with the main run in the vertical orientation and the outlet in the horizontal orientation.

Typical Applications:

- Vertical run use point, sampling and diverting.

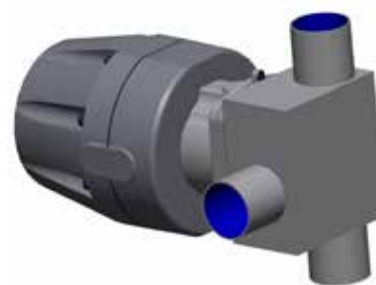

Flow Path

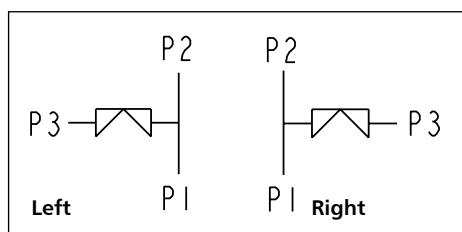
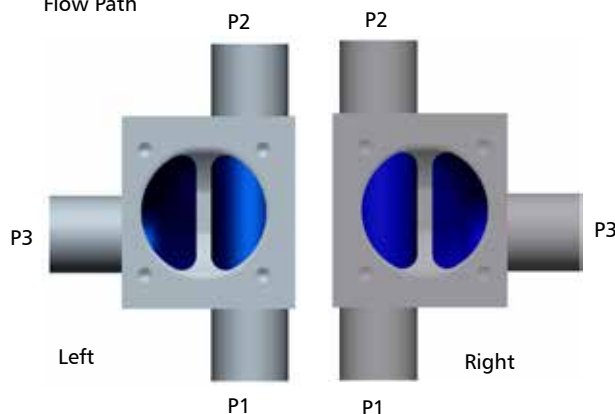

# Zero Static Use Points

## Zero Static Inverted with Drain (ZID)

Zerostatic Inverted Drain valves integrate the benefits of a zero static for low point feed or return lines while allowing for cleaning, sterilization and draining of the connected process piping.

Typical Applications:

- For line feed applications that require the ability to drain the up stream line



Flow Path

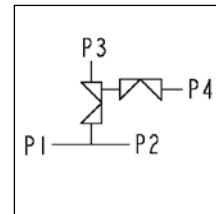

## Zero Static Block Body with Back Outlet Option (ZSBT-BO)

The ZSBT-BO valve provides all the advantages of the standard zero static valve for transferring, sampling, draining and diverting critical fluids, while minimizing the vertical space required. Porting the outlet from the back of the valve substantially reduces the space necessary when piping would require a 90° elbow to change the direction.

Typical Applications:

- Low clearance areas below WFI and process vessels.
- Skidded process systems such as CIP.

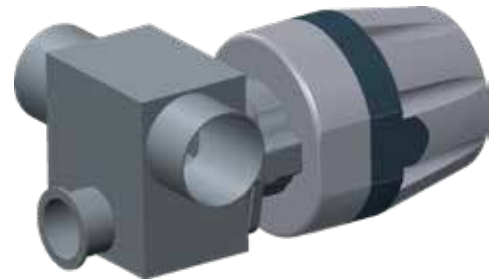

Flow Path

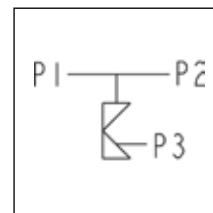
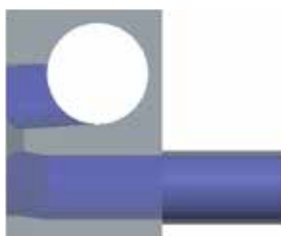

# Zero Static Use Points

## Zero Static Dual Inline (ZDI)

Zero Static use points are some of the most critical valves utilized in the Biopharmaceutical industry. Zero Statics are used extensively on Water for Injection (WFI) and purified water loops. These water loops supply nearly every manufacturing process. Water loop maintenance is typically scheduled for annual shutdowns so as not to affect production. Critical applications or use point locations that require maintenance on a more frequent basis or that would affect a large portion of the plant water loop may require additional valves to isolate the main water loop for maintenance. The Zero Static Dual Inline valve was designed specifically to allow for maintenance of two use points with minimum loop downtime.

Typical Applications:

- Use points where the loop service intervals need to be maximized

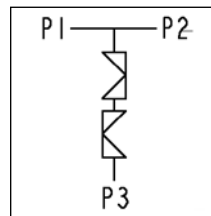
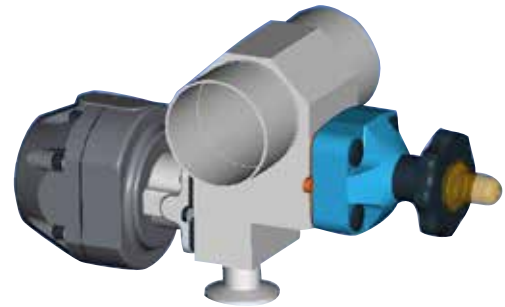

Flow Path



# Divert & Sterile Access Valves



Patent # 6,401,756

## Integral Sterile Access and GMP (ISG)

The ISG combines the functionality of the two most common process fabrications (Sterile Access (SA) and GMP) into one assembly, greatly reducing the deadlegs of conventional SA and GMP fabrications when a purge valve is required.

This is achieved by providing the purge valve integral to the main body design. By simply rotating the assembly, one fabricated block body can provide three process fabrication orientations: Standard Sterile Access Port (SA) and vertical GMP porting above and below the weir. The result is one integral valve assembly, which reduces contact surfaces and hold up volume, while minimizing dimensional envelope and increasing design flexibility.

## Typical Applications:

- Process diversion, steam barrier/block sampling

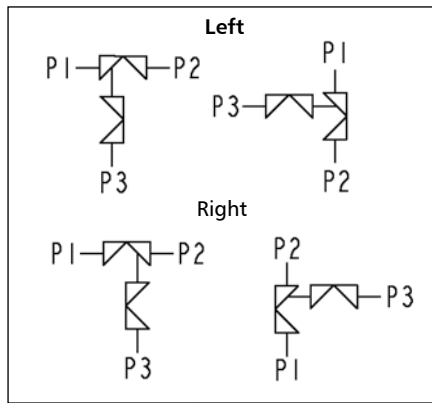

ISG

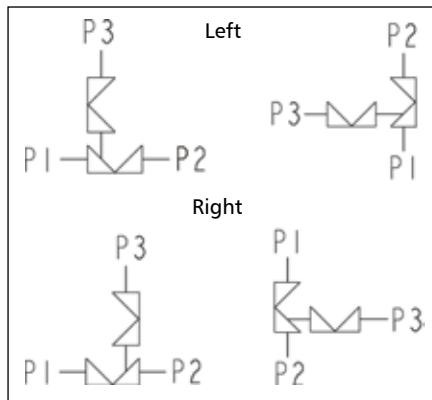

Inverted ISG

ISG Flow Path

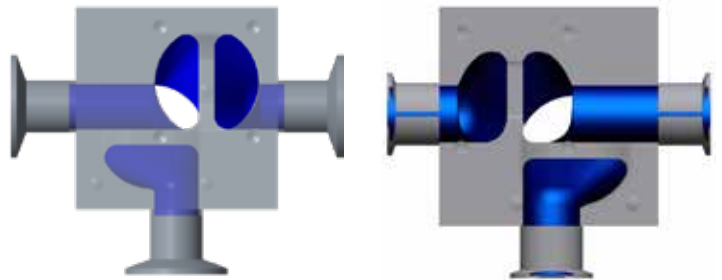

Left hand

Right hand

Inverted ISG Flow Path

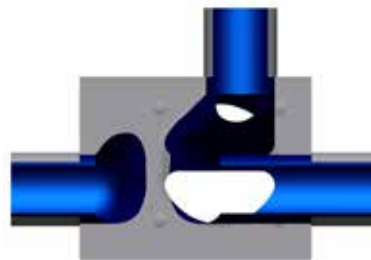

Right hand

# Divert & Sterile Access Valves

## 2 through 6-Way Multiport Divert Valves

Divert valves are instrumental in achieving efficient, cost effective piping design. Divert valves allow process fluids to be diverted, mixed and/or sampled. ITT Pure-Flo is the first in the industry to incorporate the multiple weir block design. Divert valves minimize contact surfaces, minimize hold up volume, reduce CIP cycle times, improve product purity, minimize piping dimensional envelope, reduce number of system weldments, and are more easily actuated and validated then transfer panels.

Typical Applications:

- Distribution of process flows (ie. mixing flow paths)
- 2-Way diverts are often used to switch between main and backup pumps on WFI loops
- Used in place of transfer panels
- Also used for bypass, drain and isolation
- CIP distribution
- Switching between buffers for Chromatography

Pure-Flo 2-Way Divert



Patent for 2-Way #  
6,237,637 and #  
5,427,150

EnviZion 2-Way Divert



Pure-Flo 5-Way Divert

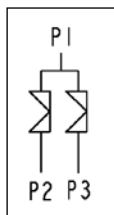

DV2W

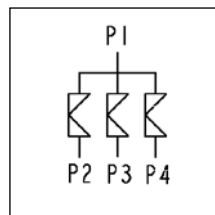

DV3W

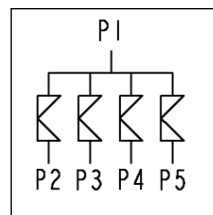

DV4W

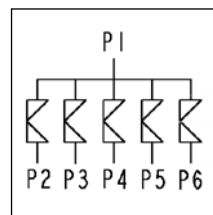

DV5W

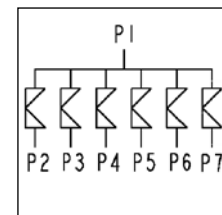

DV6W

Flow Path

2-Way (DV2W)



3-Way (DV3W)



4-Way (DV4W)



5-Way (DV5W)



6-Way (DV6W)



# Divert & Sterile Access Valves

## Divert Outlet Options

2-Way

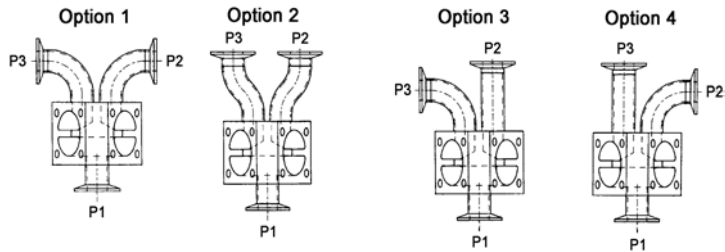

3-Way

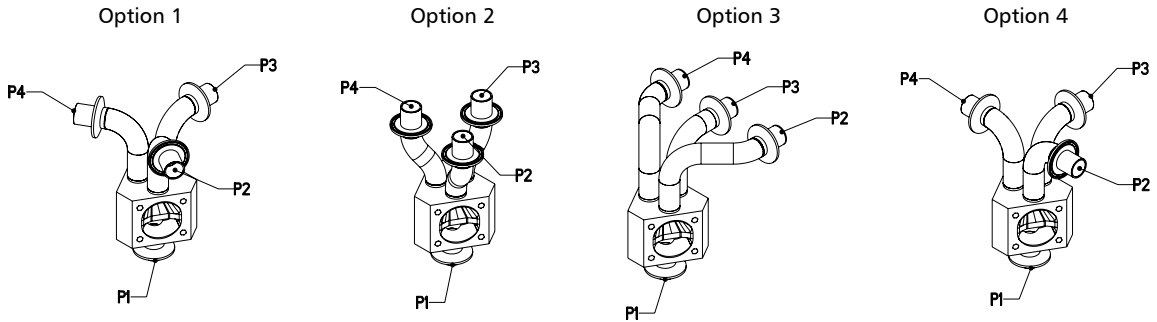

4-Way

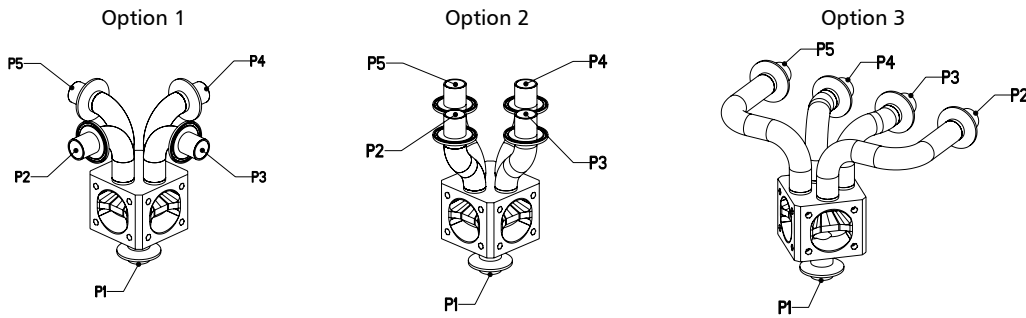

5-Way

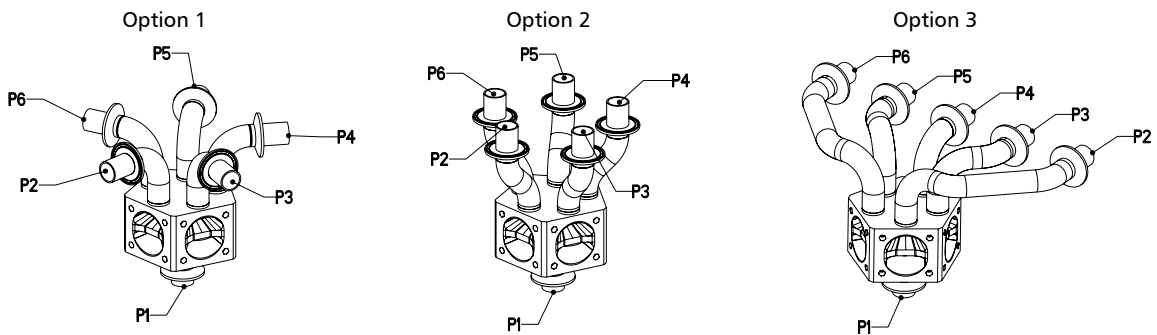

6-Way

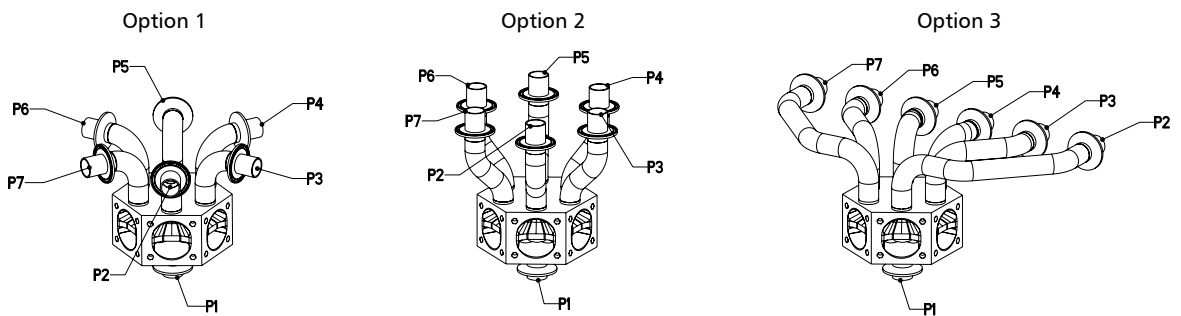

Integrated Block Valves

# Divert & Sterile Access Valves

## Chromatography Valve (CHRO & CHN)

In a typical chromatography process, there is an assembly of five diaphragm valves that connect the chromatography column to the process piping. Manipulating those valves allows the process to flow through the chromatography column in the forward and reverse direction, as well as bypass the column completely. The Pure-Flo Integral Chromatography Valve Assembly accomplishes this task by integrating the required valves while retaining flexibility, minimizing dead legs in the process piping, and reducing the overall space needed for the assembly. The Integral Chromatography Valve provides the process needs of three (3) P&IDs, utilizing four or five valves in one integrally machined assembly, dramatically reducing contact surfaces and hold up volume.

Typical Applications:

- Chromatography



Patent # 6,112,767 and 5,906,223

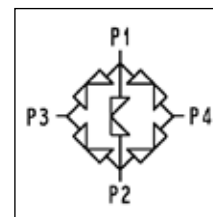

CHRO

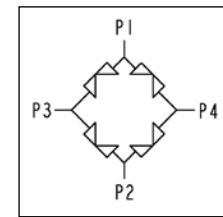

CHN

Flow Path

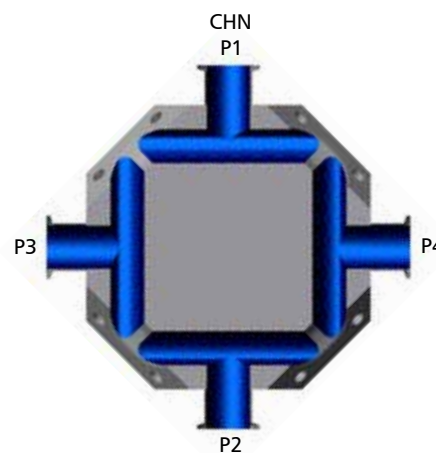
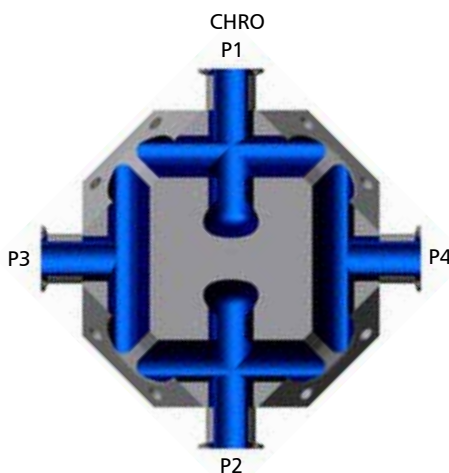

# Divert & Sterile Access Valves

## Crossover (CROD & CRO)

Bioprocessing often requires the use of flow through equipment that must be isolated for maintenance. To facilitate maintenance without shutting down the entire process a configuration of three valves is typically used to isolate and bypass when necessary. The crossover valve integrates these three valves into a single drainable block with minimized deadlegs and hold up volume.

### Typical Applications:

- Isolation and bypass of equipment such as filters, housings and bubble traps.

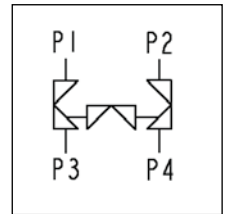
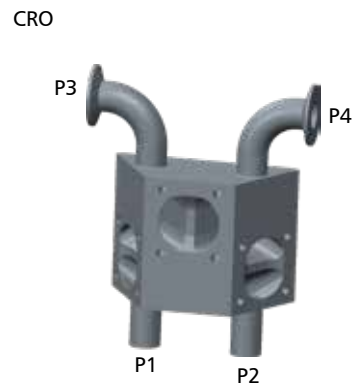
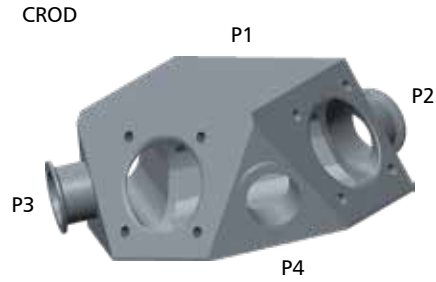

## Integral Dual Sterile Access (IDSA)

Sterile Access valves are widely used in the Biopharmaceutical industry. Sterile Access valves allow access to the process system for sterilizing, sampling, cleaning, diverting or draining. The Integral Dual Sterile Access valve integrates access on either side of the valve, with minimal deadlegs and hold up volumes. The integrated block design provides the possibility to orient the sterile access valves up or down, which can not be easily accommodated in a sterile access fabrication.

### Typical Applications:

- Cleaning/Sterilization both upstream and downstream of the control point.



Flow Path

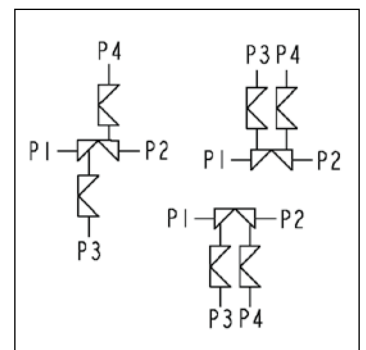
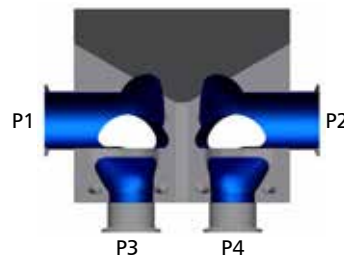

# Divert & Sterile Access Valves

## Horizontal Divert Valve 3-Way (HDV3W)

3-Way Divert valves are instrumental in achieving efficient, cost effective piping design. Divert valves allow process fluids to be diverted, mixed and/or sampled. Divert valves minimize contact surfaces, minimize hold up volume, reduce CIP cycle times, improve product purity, minimize piping dimensional envelope, and reduce number of system weldments. The Horizontal 3-way divert is specifically designed to be drainable in horizontal installations. The HDV3W is ideal for limited vertical space applications such as under process vessels.

Typical Applications:

- Divert process flow, mixing flow paths, drain and isolation
- Low vertical space installations



Flow Path

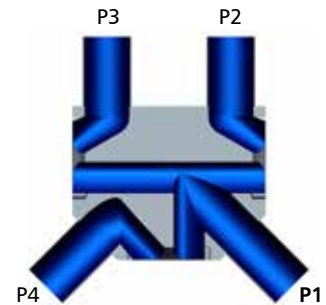
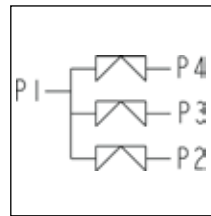

## Integral Horizontal Sterile Access (IHSA)

The Integral Horizontal Sterile Access (IHSA) is designed for sterile access applications where the piping for the main valve and purge valve are both on a horizontal plane. The IHSA provides additional benefits over standard Horizontal Sterile Access (HSA) fabrications. The IHSA should be used whenever optimal drainability and minimal deadlegs are required in horizontal orientations.

Typical Applications:

- Integral block incorporating second horizontal valve
- Ideal for vertical space constraints

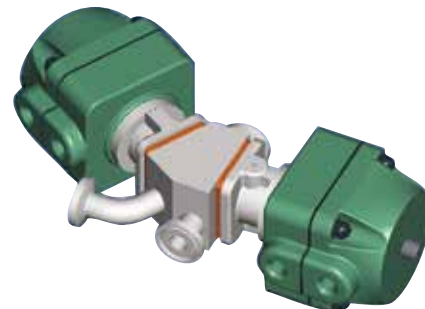

Flow Path

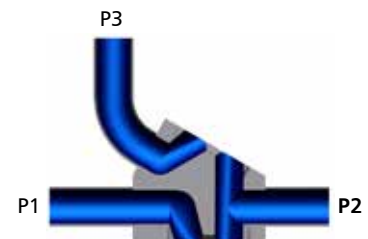
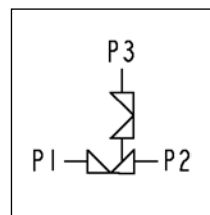

# Vessel Valves

## Tank Bottom Valve (TBV)

The Tank Bottom Diaphragm Valve is designed for use at the bottom of a tank or vessel to drain or sample while minimizing the interior sump and preventing any dead leg for bacteria or microorganism entrapment.

Typical Applications:

- Creating an aseptic barrier around bioreactors



Patent # 5,227,401

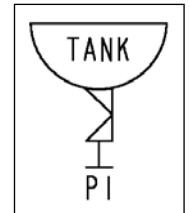

## Sterile Tank Vent Filter Shunt (DV2WS)

The DV2WS is a 2-Way Divert valve designed to facilitate changing from one vent filter to another on WFI storage tanks without interrupting operations.

Normally vent filter cartridges are not changed during operation due to potential for contamination. Large systems designed for continuous use often require two separate vent filtration units. The Sterile Filter Shunt valve is a sterilizable tank vent shunt valve assembly mounted on a single nozzle designed for this purpose.

The steam traced version of this valve when used with a steam jacketed filter housing, will prevent condensation from forming inside the filter housing. The assembly consists of a 2-way divert valve. The upstream side of the valve is connected to the two filter housings. The common port is connected to the tank vent nozzle. A steam condensate discharge port is positioned tangential to the weir of both valves. Two additional valves are used to close the condensate port after sterilization. These valves in turn are connected to a steam trap which then goes to drain.

Typical Applications:

- Used to change a vent filter cartridge on a WFI tank while the system is in operation

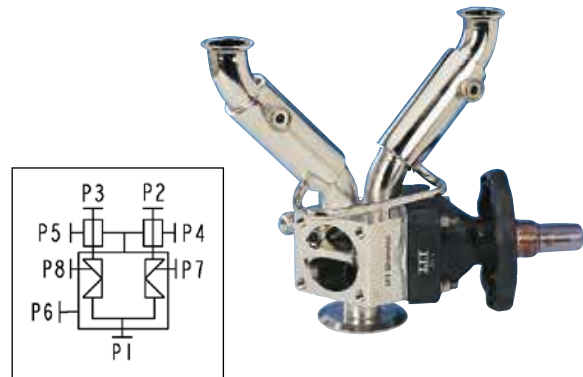

Flow Path

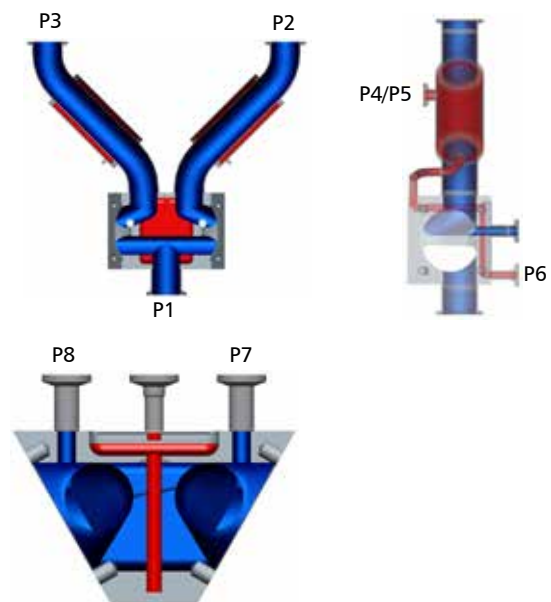

# Vessel Valves

## Block and Bleed (BBD, BBV)

The double block and bleed method of creating an aseptic barrier between two processes is widely utilized in the Bioprocessing industry. Traditionally three standard valves would be fabricated into the double block and bleed configuration. The Block and Bleed Drain (BBD) and Block and Bleed Vent (BBV) valves integrate these three valves into one compact block, minimizing hold up volumes and enhancing cleanability. The compact design allows for greater valve density and flexible system design.

Typical Applications:

- Create steam block, isolate and clean chamber for aseptic barrier
- Block line flow for the purpose of draining the line or filling from an auxiliary source

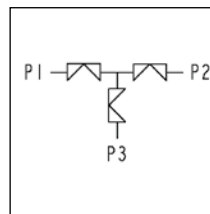
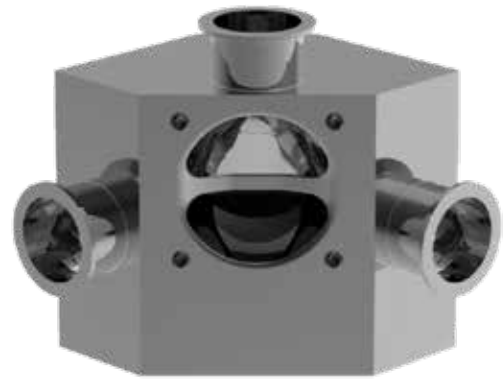

Block & Bleed  
Code: BBD

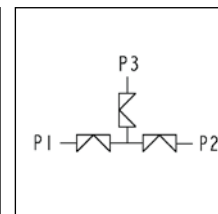

Block & Bleed  
Code: BBV

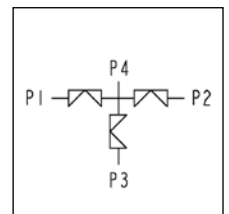

Block & Bleed with  
Optional Vent Port  
Code: BBD-VP

## Flow Path

BBD



BBV

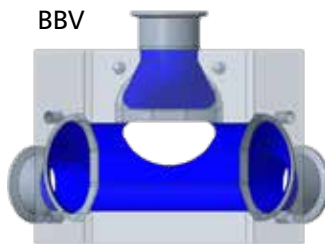

## Bypass or Dual Flow (BYP, DF)

Typical Bioprocessing and Pharmaceutical processes utilize large quantities of water. Processes such as WFI storage, Media hold and Buffer preparation utilize large vessels for holding or preparing the process fluids. The Bypass valve is specifically designed to optimize the fill rate of these large vessels. By utilizing two different flow paths the process can be filled quickly with the larger valve and filled at a slower rate by the smaller valve for topping off the process, saving significant time in the process.

Typical Applications:

- Tank filling applications



## Flow Path

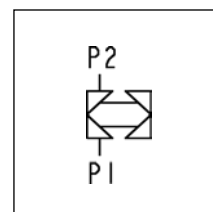
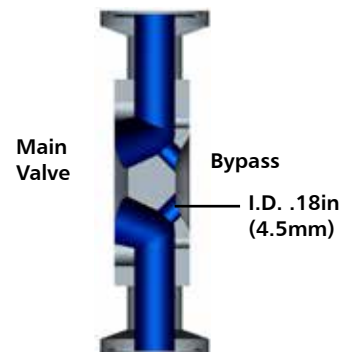

Bypass  
Code: BYP

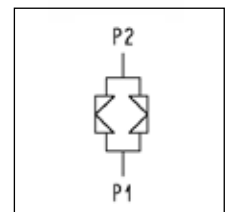
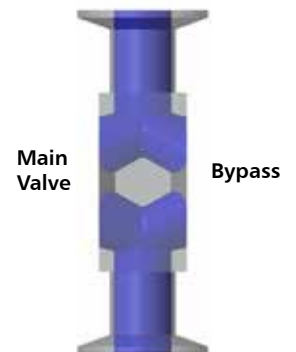

Dual Flow  
Code: DF

# Vessel Valves

## Integral Sterile Barrier (SB1)

The Sterile Barrier block addresses the issues of achieving sterile barrier technology and utilizing a small dimensional envelope while minimizing contact surfaces and hold up volume. The Integral Sterile Barrier consists of four valves machined from a single block. The common chamber is located in the center of the block and the independent ports are located on the ends. The assemblies consist of two product valves, a steam injection valve and a condensate drain valve. When the two product valves are open and the steam injection and condensate valves are closed, product flows through to the reactor. When the product valves are closed, a chamber is formed between the two valves which, when injected with steam, provides a sterile barrier isolating the reactor.

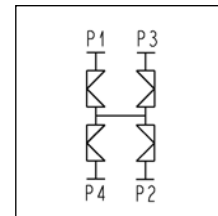

## Typical Applications:

- Creating an aseptic barrier around bioreactors

### Flow Path

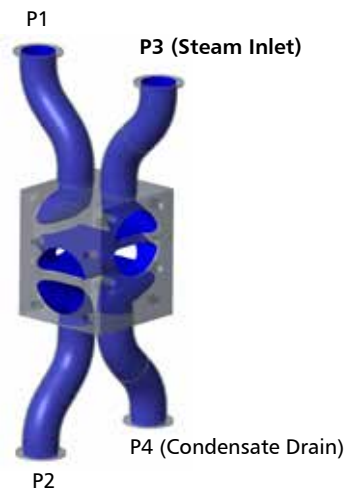
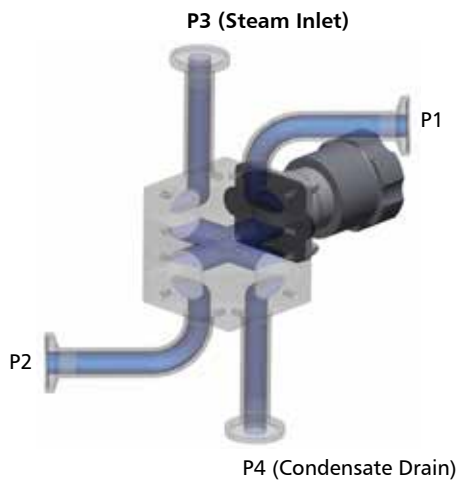

# Section D

# Diaphragms

ITT has manufactured diaphragm valves for nearly 60 years and takes great pride in its reputation for supplying the highest quality hygienic diaphragm valves to the Biopharm industry.

The diaphragm is the most critical component of a diaphragm valve. Diaphragms are the valve component that provide positive shut-off between process fluids, protects the process from the environment and in some cases protects the environment from the process.

Genuine ITT diaphragms feature:

- Designs specifically matched to Pure-Flo weir geometry
- Engineered safety
- Reliability
- Industry proven performance
- Reduced total cost of ownership
- Complete product range
- Pure-Flo Topworks compatibility
- Material traceability permanently marked on diaphragms
- Original Equipment Manufacturer (OEM) materials and specifications
- Global availability
- Global technical support
- Preventative maintenance program development assistance

Regulatory Compliance to:

- FDA 21CFR Part 177
- US Pharmacopeia Class VI
- EMEA/410/01 - TSE/BSE (Transmitting Animal Spongiform Encephalopathy)

ITT Pure-Flo diaphragms are qualified and approved for use with Pure-Flo diaphragm valves. Other makes of diaphragms are not recommended and/or guaranteed by Pure-Flo for use with Pure-Flo valves.

## Table of Contents

Diaphragm Selection . . . . .	D2
Principles of Operation . . . . .	D3
Bio-Pure and EnviZion Mode of Operation . . . . .	D4
Diaphragm Construction . . . . .	D5
Grade TME & TMZ PTFE Diaphragms . . . . .	D6
Grade E1 EPDM Diaphragm . . . . .	D7
European Pressure Equipment Directive . . . . .	D8
Pressure/Temperature Recommendations . . . . .	D9
PTFE Diaphragm for Vacuum Service. . . . .	D10
Validation & Compliance . . . . .	D11
Diaphragm Traceability. . . . .	D12
Packaging & Storage . . . . .	D13
Application . . . . .	D14



Standard Pure-Flo



EnviZion

# Diaphragm Selection

The Pharmaceutical and Biotech industries consider a number of factors to determine the best diaphragm solution for a given process or application.

Key factors include:

- Regulatory Compliance
- Biocompatibility
- Material extractables
- Application temperatures
- Cleaning in place (CIP)
- Steaming in place (SIP)
- Passivation
- Failure mode



Applications within the Biotech industry are particularly sensitive to diaphragm materials because of the fact that many of the processes within the industry utilize living organisms. A balance or compromise must be struck between all of the key factors listed. Regulatory compliance in most cases is not sufficient by itself to guarantee a properly functioning system.

The worldwide network of ITT Pure-Flo technical resources are available to assist in determining the proper diaphragm for your application.

	Diaphragm Type		Size		Temperature		Compliance		
	Grade	Material	Inch	DN	°F	°C	FDA	USDA	USP
P	B	Black Butyl Rubber	0.50-4	15-100	-20-250	-29-121	✓	✓	
P	E1	EPDM <sup>1</sup>	0.25-4	6-100	-22-302 <sup>2</sup>	-30-150	✓		✓
P	P	Buna N	0.50-4	15-100	10-180	-12-82	✓	✓	
P	TME	PTFE	0.25-4	6-100	-4-329	-20-165	✓		✓
E	TMZ	PTFE	0.25-2	15-50	-4-329	-20-165	✓		✓
P	W1	White Butyl Rubber	0.50-4	15-100	0-225	-18-107	✓	✓	

<sup>1</sup> For high temperature and/or high cycle applications, contact ITT.

<sup>2</sup> Temperature range is as follows:

-4-194°F (-20-90°C) for liquid applications

-22-285°F (-30-140°C) for continuous steam

-22-302°F (-30-150°C) for intermittent steam

# Principle of Operation

Pure-Flo's two-piece PTFE diaphragms have proven through years of outstanding service to be a robust and forgiving design. The two-piece construction eliminates the delamination problems inherent in competitive "PTFE faced" diaphragms.

PTFE diaphragms utilize a floating tube nut connection. The floating tube nut design assures that downward closing forces will be absorbed by the elastomer backing cushion and evenly distributed across the closing surface (weir) in the valve body.

## Design Benefits:

- Reduced cold flow
- Improved sealability
- Longer diaphragm life
- Reduced point loading
- Eliminates stud pullout

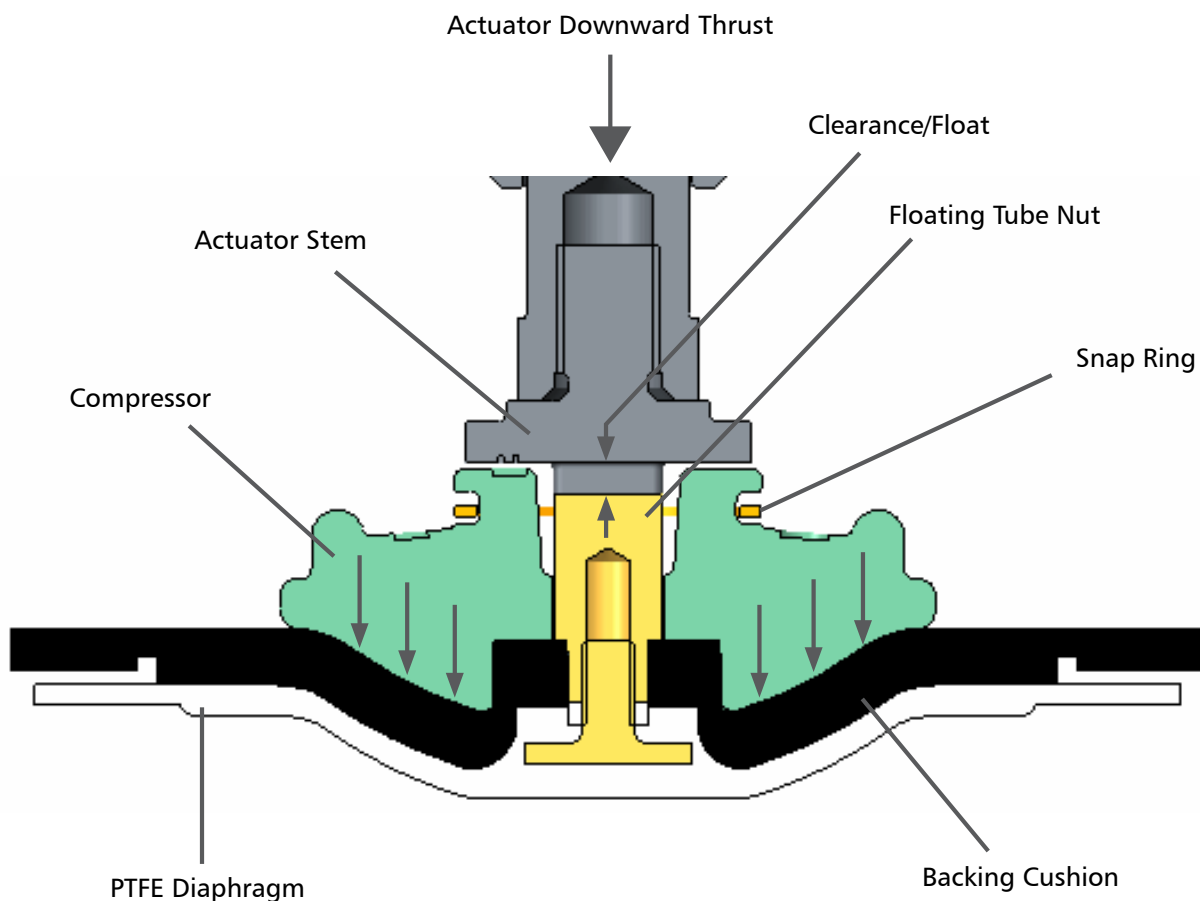

# Mode of Operation

## Bio-Pure Interchangeability

All Bio-Pure valves feature a common diaphragm connection. Elastomer and PTFE diaphragms can be interchanged as required on both the manual and actuated bonnets.

## Bio-Pure Installation

Bio-Pure diaphragm installation is simplified by utilizing a bayonet diaphragm connection. The diaphragm is inserted into the compressor and turned 90°. The bayonet design provides float to eliminate point loading on PTFE diaphragms.

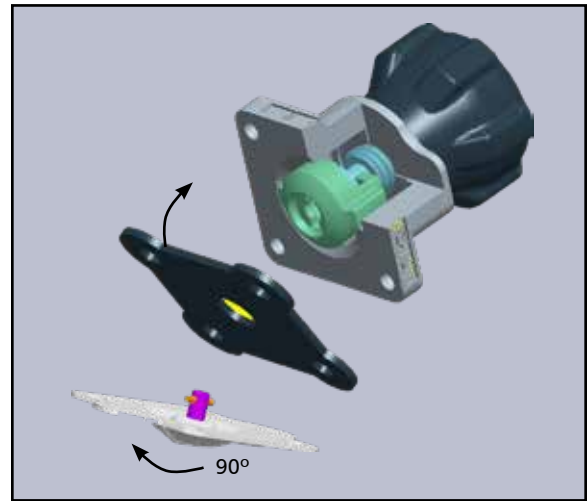
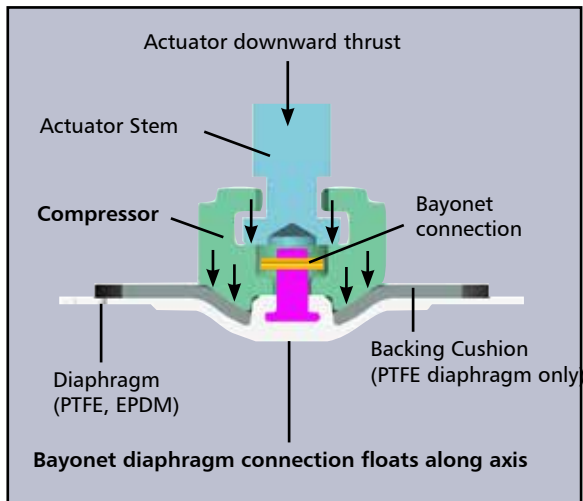

## EnviZion

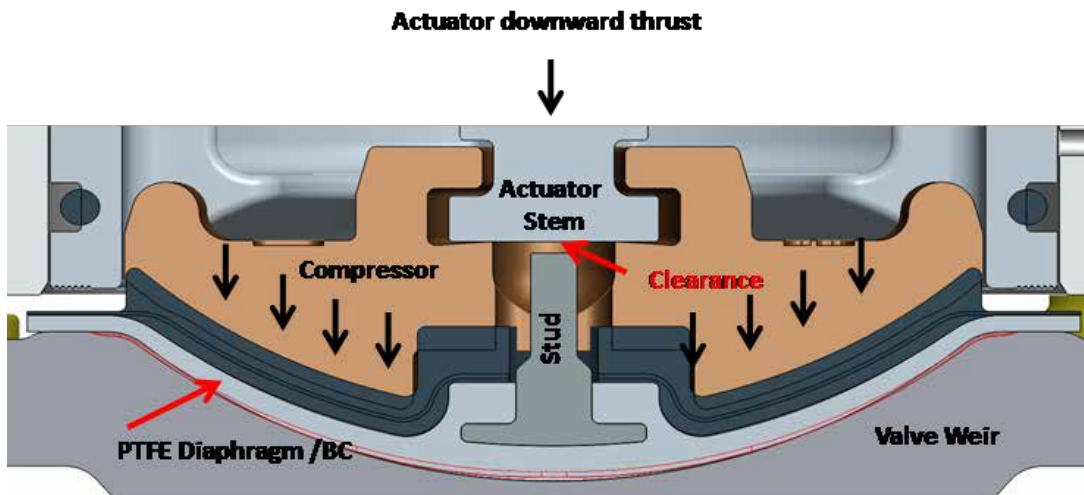

# Diaphragm Construction

Pure-Flo elastomer diaphragms are produced by a compression molding process. The completed elastomer diaphragm is of a one-piece design. The diaphragm is constructed with layers of polymer material and a high performance woven fabric reinforcement for maximum strength and durability.

Elastomer diaphragms utilize a threaded connection to the valve compressor. PTFE and Elastomer diaphragm threads are not interchangeable.

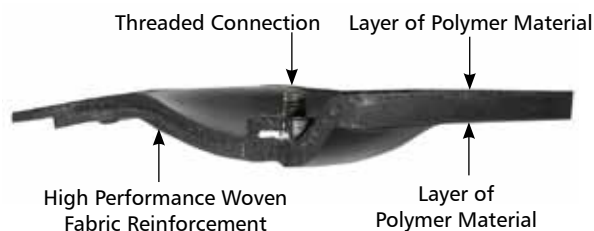

## Qualification Testing

Quality, performance and reliability of all Pure-Flo diaphragms is assured through extensive testing and comprehensive controls on the diaphragm material manufacturing process. Pure-Flo has years of experience in the development of diaphragm materials for use in the challenging applications within the Pharmaceutical and Bioprocessing industries. This knowledge is applied to each new material development. Successful completion of all appropriate regulatory requirements and operational performance benchmarks must be met before any new diaphragm material is released to the industry.

Typical conformance and performance tests:

- FDA extraction per 21CFR177.2600 (Elastomers)
- FDA extraction per 21CFR177.1550 (PTFE)
- USP <87> and USP <88> (Class VI)
- Cycle testing using air, water, and steam
- Cycle testing against vacuum and positive pressure at 100% and 0%  $\Delta P$  conditions
- Cycle testing at ambient, cold, and elevated temperatures

Note: ITT Pure-Flo diaphragms are qualified and approved for use with Pure-Flo diaphragm valves. Other makes of diaphragms are not recommended and/or guaranteed by Pure-Flo for use with Pure-Flo valves.

Diaphragm Development



## USP Class VI

Pure-Flo PTFE diaphragms are tested to USP standards at 121°C to provide assurance that diaphragm materials do not affect the process when subjected to typical protocols.

# Grade TME & TMZ PTFE Diaphragms

## P Standard Pure-Flo Diaphragm - TME

Grade TME combines the performance of the Grade TM PTFE diaphragm with a Grade B1 EPDM backing cushion that has been specifically formulated and processed to enhance material properties. Backing cushion compression and extrusion has been minimized with these changes. As a result diaphragm performance is improved in thermal cycling applications.



## E EnviZion Diaphragm - TMZ

The EnviZion diaphragm TMZ has been developed to withstand the wear of today's production cycles and maintain a reliable seal, avoiding the risk of leakage and batch contamination. It combines advanced technology with proven materials that are used extensively in the Pharmaceutical and Biopharm industries.

Featuring a robust 2-piece construction, the EnviZion diaphragm utilizes the same modified PTFE material as the Pure-Flo series of valves with an enhanced EPDM backing cushion. The diaphragm design has been optimized to maximize sealing efficiency while minimizing stresses during operation.



## P E PTFE Diaphragms

Type: TME & TMZ

Size Range: TME: BT-4" (DN6 - DN100)  
TMZ: .5-2" (DN15 - DN50)

Temperature Rating:  
-4°F to 329°F (-20°C to 165°C)

Pressure Rating:  
See Pressure & Temperature chart on page D-9

Material (2 Piece Construction):  
Product Contact Surface: Modified PTFE with PPVE\*  
Backing Cushion: Grade B1 EPDM

Regulatory Compliance:

21 CFR 177.1550 (PTFE)

21 CFR 177.2600 (Backing cushion)

USP <87> and USP <88> (Class VI)

\*TME Material is considered a homopolymer according to ISO 12086, ASTM D-4894 due to < 1% perfluoropropyl vinyl ether (PPVE) modification

# Grade E1 EPDM Diaphragm

**P** Created with the latest advanced technology polymer science. The NGE (E1) diaphragm was developed specifically for the intense applications of the Biopharmaceutical industry, the Pure-Life NGE diaphragm outperform all previous classes of EPDM and EPM diaphragms in these applications. Testing in extreme conditions both at ITT's state of the art diaphragm development laboratory and prominent Biopharm end users has shown order of magnitude performance gains over current generation of EPDM diaphragms.

**Type:** E1

**Size Range:** BT-4" (DN6 - DN100)

**Temperature Rating:**

- -4–194°F (-20–90°C) for liquid applications<sup>1</sup>
- -22–285°F (-30–140°C) for continuous steam<sup>1</sup>
- -22–302°F (-30–150°C) for intermittent steam<sup>1</sup>

**Pressure Rating:**

See Pressure & Temperature chart on page D-9  
Consult factory for steam rating

**Material:**

Ethylene Propylene Diene Monomer  
Peroxide Cured (EPDM)

**Regulatory Compliance:**

21CFR 177.2600  
USP <87> and USP <88> (Class VI)

<sup>1</sup> For high temperature and/or high cycle applications, contact ITT.

**Benefits:**

- Reduced total cost of ownership
- Extended service life
- Improved uptime
- Ease of validation
- Improved resistance to steam, WFI and commonly used CIP chemicals
- Maintains ITT valve warranty



**Certifications:**

USP <87> and USP <88>  
(Class VI) Compliant  
FDA 21CFR177.2600 compliant  
Conforms to ASME BPE SD-2.6  
Animal-derived Ingredients  
EMEA /410/01 TSE/BSE (Transmitting  
Animal Spongiform Encephalopathy)  
compliant

# European Pressure Equipment Directive 97/23/EC

Diaphragm valves must comply with European Union Pressure Equipment Directive 2014/68/EU. Valves must meet certain Essential Safety Requirements and design criteria. This includes diaphragms as they are an integral component of the valve pressure boundary.

The PED requires the manufacturer to maintain a technical file primarily consisting of:

- Design calculations or proof test
- Material testing
- Performance testing
- Declaration of Compliance to the PED 2014/68/EU (available on request)

An excerpt from a guideline for the Pressure Equipment Directive 2014/68/EU states:

“Pressure equipment which has been subject to important modifications that change its original characteristics, purpose and/or type after it has been put into service has to be considered as a new product covered by the directive.”<sup>1</sup>

Note:

The use of unauthorized and therefore undocumented components within the valve constitutes a major modification to the valve and renders the original ITT Declaration and compliance to the Directive invalid. The end user or the supplier of the unauthorized replacement component must take the responsibility for compliance to 2014/68/EU.

<https://ec.europa.eu/docsroom/documents/41641>

## Pressure Boundary

The diaphragm is a critical pressure boundary component of a typical diaphragm valve in conjunction with the valve body, fasteners and manual or actuated bonnet. These components are designed, manufactured and tested to achieve specific pressure ratings and performance criteria. Changes in materials, dimensions or even tolerances of any of these components can have an adverse affect on the overall performance and safety of the valve. ITT Pure Flo conducts extensive testing to support the performance of the valve and pressure boundary.

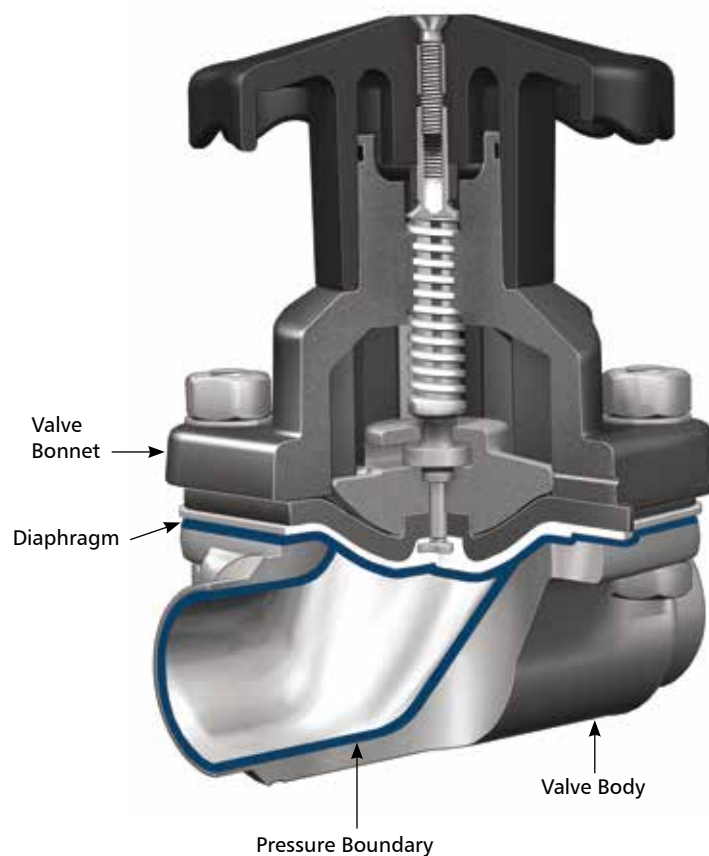

# Pressure/Temperature Recommendations

## P Standard Pure-Flo Valve

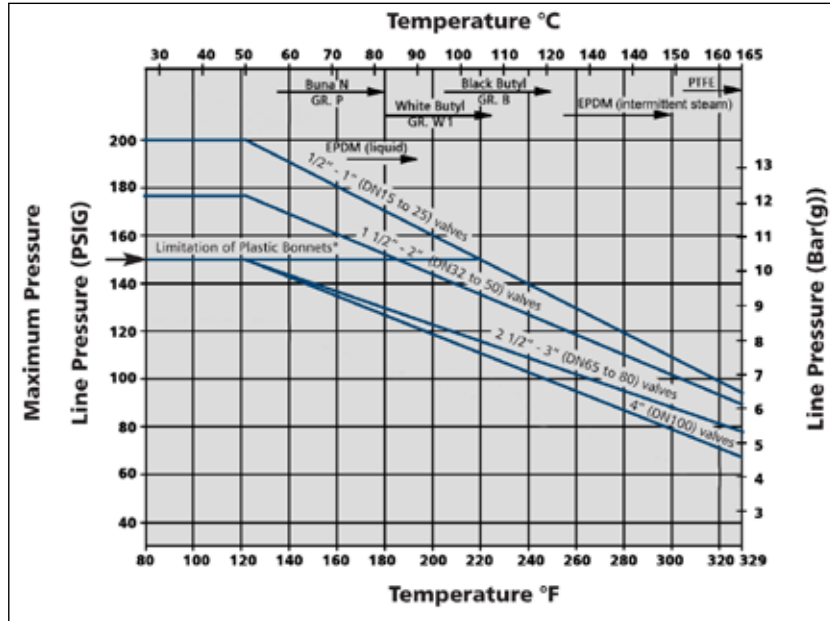

\* This line shows the limitation of plastic bonnets including the 963 and Advantage Actuators.  
 Note: Elastomer diaphragms may be used in vacuum service within above temperature recommendations. For services exceeding charted pressure/temperature recommendations, consult factory. The chart does not pertain to steam or corrosive services. Consult ITT Dia-Flo Technical Manual and Service Guide for specific recommendations.

## E EnviZion Valve

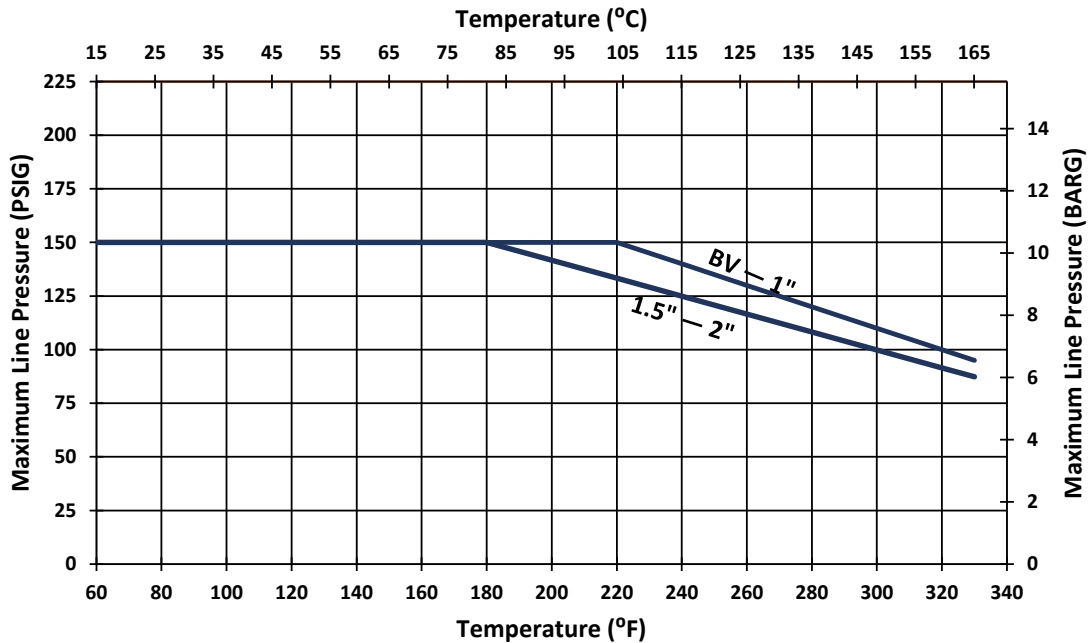

# PTFE Diaphragms for Vacuum Service

## P Standard Pure-Flo Valve

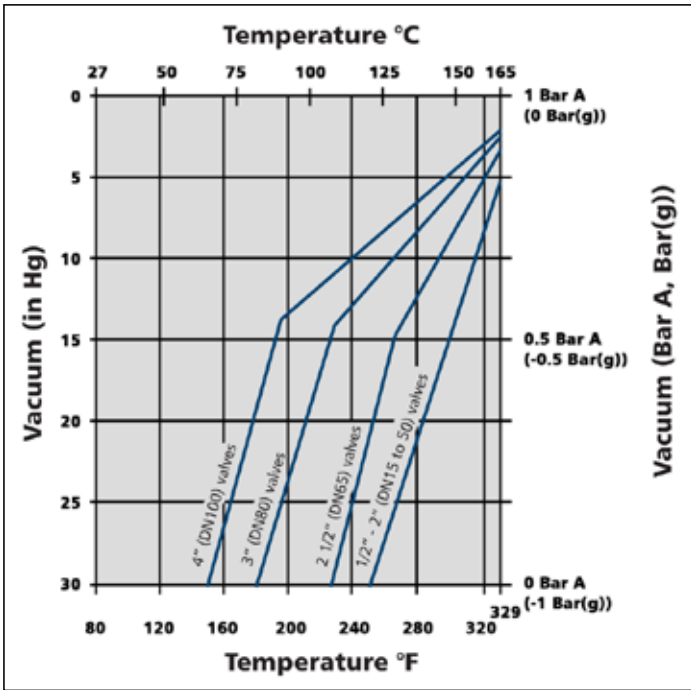

Notes:

1. Service conditions falling to the right of these lines will require bonnet evacuation.
2. With evacuated bonnets any size PTFE-Diaphragms can be used up to 329°F (165°C).
3. See below for elastomer diaphragms for vacuum service

## Pure Flo Elastomer Diaphragms for Vacuum Service

The standard Pure-Flo diaphragm valve is ideally suited for vacuum service, providing dependable performance and good service life from atmospheric pressure down to nearly full vacuum (-30 in Hg, 0 Bar A) The diaphragm is bi-directional and presents a smooth face with no hidden voids on either side of the valve, whether open, closed or throttling.

## E EnviZion Valve

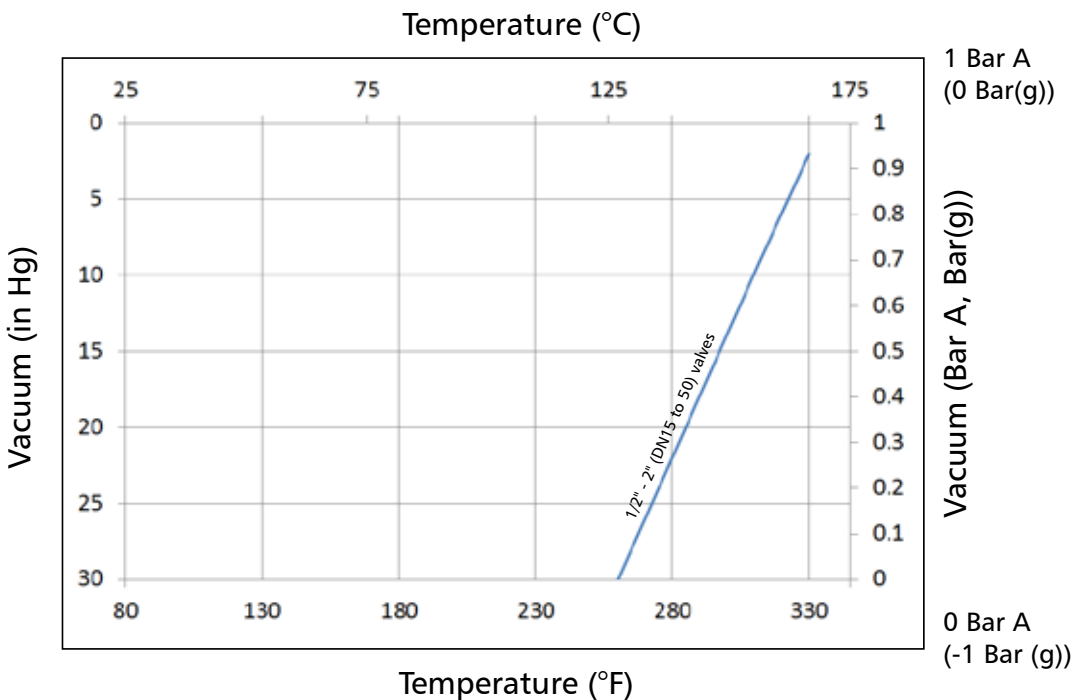

# Validation & Compliance

ITT Pure-Flo recognizes the importance of product and process validation to the Pharmaceutical and Bioprocessing industries. A complete selection of documentation is available to facilitate the validation process.

- Diaphragm ingredients and processing aids are FDA compliant
- Physical properties, raw materials, compounding and molding process are documented
- All diaphragms are available with FDA Certificate of Conformance
  - 21CFR177.2600 (Elastomers)
  - 21CFR177.1550 (PTFE)
- All diaphragms are available with USP Certificate of Conformance
  - USP <87> In-Vitro
  - USP <88> (Class VI) In-Vivo
- Certificate of Compliance to EMEA/410/01 “Guidance on Minimising the Risk of Transmitting Animal Spongiform Encephalopathy Agents via Human and Veterinary Medicinal Products” available upon request
- Certificate of Traceability to EN 10204 3.1 B available upon request
- Third party testing and in-house performance data available upon request

Note: ITT Pure-Flo diaphragms are qualified and approved for use with Pure-Flo diaphragm valves. Other makes of diaphragms are not recommended and/or guaranteed by Pure-Flo for use with Pure-Flo valves.

## Certificates of Compliance



ITT Engineered Valves, LLC  
33 Centerville Road  
Lancaster, PA 17603-2064  
Phone: (800) 365-1111  
Fax: (1717) 559-0398

---

**CERTIFICATE OF COMPLIANCE/ CONFORMANCE**  
Date Issued: August 10, 2023

---

<b>Customer:</b> Sample Cert	<b>Quantity:</b> 100
<b>Customer Order Number:</b> XXXXXX	
<b>ITT Order Number:</b> 400	Sample E1 Diaphragm
<b>ITT Line Number:</b> 45607	
<b>ITT Part Number:</b> 45607	

---

<b>Figure Number (Description)</b>	46607 - DIAPHRAGM WR 02.00 MC EPDM E1
------------------------------------	---------------------------------------

---

<b>Additional Information</b>	<b>Part No</b>	<b>Description</b>	<b>Qty</b>	<b>Date Code</b>	<b>Cure Date</b>	<b>Lot No</b>	<b>Exp. Date</b>
	46607	DIAPHRAGM W/ 02.00 MC EPDM E1	100	N/A	02/2023	9156688	02/2029

Extra Description: Grade E1: Grade E1 (EPDM) diaphragms have a LIMITED SHELF LIFE of 6 years.  
Grade E1 (EPDM) diaphragms comply with the FDA Code of Federal Regulations Title 21 Section 177.2600 with the exception of paragraph (f) "Rubber articles intended for repeated use in contact with fatty food".  
Grade E1 (EPDM) diaphragms meet USP <87> Elution Test (MEM) for Cytotoxicity and USP <88> tests for Class VI designation.  
The maximum temperature rating for Grade E1 (EPDM) diaphragms is:  
194° F (90°C) for liquid applications,  
285° F (140°C) for intermittent steam,  
302° F (150°C) for continuous steam.  
Grade E1 (EPDM) Conforms to ASME BPE SD-2.6 Animal-Derived Ingredients.  
Grade E1 (EPDM) complies with EMEA/410/01 Rev. 3 July 2011.  
Grade E1 (EPDM) meets ASME BPE Part 3G, Section 3.3 & 3.4  
Grade E1 (EPDM) is peroxide cured.  
Grade E1 (EPDM) is not made with natural rubber latex.

Storage: Until the elastomer parts are installed, they should be kept in a covered, adequately ventilated, and dry location in their original containers. Storage temperature should not cycle rapidly; should be maintained between 40 and 120 degrees F.

We certify that the components on the above referenced purchase order meet the requirements of the purchase order, applicable drawings, and our ISO 9001:2015 manufacturing, testing, and inspection procedures to assure an acceptable quality level applicable to the product; these items are supplied in accordance with QMS Manual Rev 32 dated April 06, 2020.

  
**Craig Stitzel**  
Manager, Quality Assurance (or representative)  
(This Certificate was created electronically and is valid without signature)

## Genuine Replacement Parts

Replace the diaphragm in your ITT hygienic diaphragm valve with imitation diaphragms and you might risk more than you thought. Only one diaphragm is specifically designed and manufactured to deliver the performance you demand from your ITT valve. With an ITT diaphragm valve you get compliance with FDA, USP, and ASME BPE requirements, a design that creates a tight repeatable seal, and materials that protect your process and are completely traceable. And just as importantly, you have a valve that provides essential pressure containment protecting your plant and your people.

# Diaphragm Traceability

All diaphragm materials and physical properties are batch traceable via permanent codes molded into the diaphragm tabs. The molding date, material grade, and diaphragm size provide traceability to original batch records.

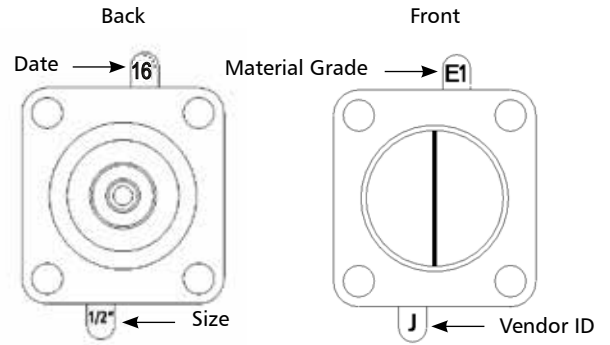

## Elastomer Material Grade Codes

Elastomer material grades are listed on page D-2 (Type 1). For diaphragms with a clock (Type 2) the arrow points to the material grade.

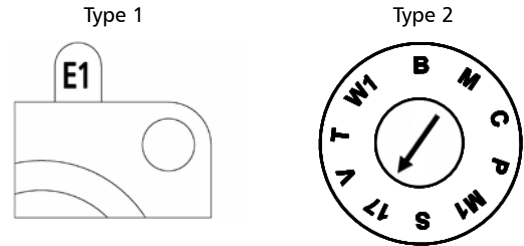

## Elastomer Date Codes

The date is a two digit year code and dots corresponding to months  
 Type 1: April 2014

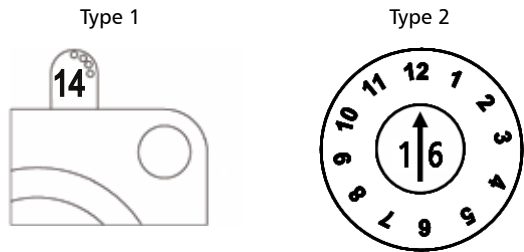

For diaphragms with a clock, the two digits in the middle are the year and the arrow points to the month.

Type 2: December 2016

## PTFE Date Codes

The first letter identifies the month the lot was manufactured. For a two digit code, the second digit is the year (Type 1: B7 = February 2017). For a four digit code, the next two digits indicate the year, and the last number indicates the batch number (Type 2: B171 = February 2017, batch 1).

PTFE Code - Months	
A	January
B	February
C	March
D	April
E	May
F	June
G	July
H	August
I	September
J	October
K	November
L	December

PTFE Code - Year		
Year	4 Digit Code	2 Digit Code
2010	10	0
2011	11	1
2012	12	2
2013	13	3
2014	14	4
2015	15	5
2016	16	6
2017	17	7
2018	18	8
2019	19	9
etc.	etc.	etc.

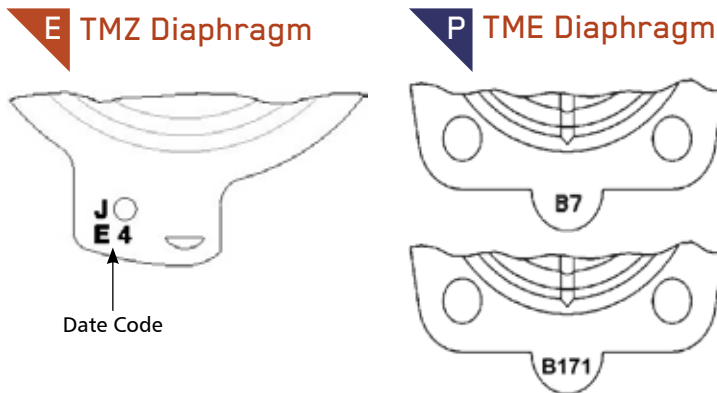

# Packaging & Storage

## Packaging

All Pure-Flo diaphragms are sealed in individual tamper evident packages to prevent damage and contamination during transportation, handling and storage. Tamper evident packaging provides an extra level of assurance that the diaphragm has not been exposed to potential contamination during storage or maintenance activities prior to installation.



All Pure-Flo Diaphragm packages contain important information necessary for validation and maintenance.

- Diaphragm part number
- Description
- Material
- Pack date
- Cure date
- Installation graphic

## Storage Recommendations

- Storage temperature should be between 40-75°F (5-25°C). Higher temperatures may affect overall service.
- Diaphragms should be stored in a cool dry environment so that condensation does not occur.
- Diaphragms should be protected from direct sunlight and Ultra Violet light sources.
- Where possible diaphragms should be protected from circulating air. Storage in bags or other air tight containers is recommended for longest service life.
- Physical properties and performance of rubber diaphragms can deteriorate when stored for long periods. The diaphragm may become unsuitable for service due to environmental, physical, and chemical factors.

## Shelf Life

Material	Grade	Shelf Life
Butyl	B, W1	10
EPDM	E1	6
Buna N	P	6
PTFE <sup>1</sup>	TME, TMZ	10

<sup>1</sup> PTFE diaphragm face only.

# Application

Pure-Flo diaphragms are suitable for a wide range of utility and process applications utilized in the Pharmaceutical and Biotech industries. However, not all diaphragm materials are suitable for all processes and conditions. The accompanying tables should be used as a reference.

The worldwide network of ITT Pure-Flo technical resources are available to assist in determining the proper diaphragm for your application.

Typical Process Applications:

- WFI
- Purified water
- Product solutions
- Buffer solutions
- Cell culture solutions
- Media
- Solvents
- Protein solutions
- Ultra filtration

Typical Utility Applications:

- Passivation protocols
- Cleaning protocols
- Sterilization protocols

## Passivation

	Nitric Acid 15% <sup>1</sup>	Phosphoric 10% <sup>1</sup>	Citric Acid 15% <sup>1</sup>	Mixed Chelants <sup>2</sup>
PTFE	R	R	R	R
EPDM	U	R	R	R

<sup>1</sup> At 140°F/60°C

<sup>2</sup> Ammonium citrate Base at 176°F/ 80°C

R = Resistant

U = Unsatisfactory

## Cleaning

	Sodium Hydroxide NaOH	Sodium hypochlorite NaOCl	Potassium Hydroxide KOH	Phosphoric Acid H3PO4	Hydrogen Peroxide H2O2
PTFE	R	R	R	R	R
EPDM	R	R	R	R	R

Consult factory for specific temperature and concentration limitations.

R = Resistant

U = Unsatisfactory

## Sterilization

	Saturated Steam <sup>1</sup>			Dry Heat <sup>2</sup>	Ozone <sup>3</sup>
	20 psi 1.4 Bar(g)	30 psi 2.1 Bar(g)	40 psi 2.8 Bar(g)		
PTFE	R	R	R	R	R
EPDM	R*	R*	R*	U	R

<sup>1</sup> 20psi/1.4 Bar(g) = 259°F/ 126°C

30psi/2.1 Bar(g) = 274°F/ 135°C

40psi/2.8 Bar(g) = 286°F/ 142°C

<sup>2</sup> 329°F/165°C

<sup>3</sup> 3% at 80°F / 27°C

R = Resistant

U = Unsatisfactory

\* Limited life and undesirable failure mode

The Pure-Flo product offering continues to evolve to meet the needs of the Bioprocessing industry. A complete line of manual and pneumatically actuated options are available to suit most any requirement. All Pure-Flo topworks are robustly designed and constructed of durable FDA compliant materials. With decades of proven reliability and long cycle life, Pure-Flo actuators are the route to trouble free operation and reduced total cost of ownership.

## Table of Contents

Manual	
EnviZion. . . . .	E2-3
970 . . . . .	E4
963 . . . . .	E5-6
Bio-Pure. . . . .	E7-8
Bio-Tek. . . . .	E9
913 . . . . .	E10
903 . . . . .	E11
Actuated	
EnviZion. . . . .	E12-13
Advantage 2.1 . . . . .	E14-15
Advantage Compact Stainless. . . . .	E16-17
Advantage Series 33. . . . .	E18
Advantage Series 47. . . . .	E19
Dia-Flo. . . . .	E20

# EnviZion<sup>®</sup> Manual Bonnet

**E** ITT's breakthrough technology, the EnviZion valve, sets a new standard for the future of hygienic diaphragm valves. The EnviZion valve is designed specifically to help customers install, operate, and maintain their valves more efficiently. This unique design provides a significant reduction in total cost of ownership while supporting the industries' goals to increase productivity, improve reliability and enhance cleanability.

Type: ZH, ZHS (sealed)

Size Range: .5-2 inch (DN15-50)

Max Service Temperature:  
See page D-9

Bonnet Material: Stainless steel

Handwheel/Bonnet Cover: FDA  
21CFR177.1660 compliant PES

Corrosion Resistance:  
Resistant to common industry washdowns. For specific chemical resistance, consult factory.

Standard Features:

- Autoclavable
- Thermal compensation system
- Safety lock-pin
- Travel stop
- Visual position indication
- Weep hole

Patents can be found at;  
[www.engvalves.com/Special-Pages/Pat/](http://www.engvalves.com/Special-Pages/Pat/)

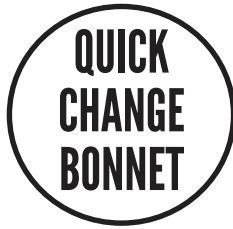

TOOL-LESS  
ASSEMBLY



CONTAMINATION  
FREE



SEALING SYSTEM  
3RD PARTY  
CERTIFIED



ZERO  
RETORQUES



LEAK FREE  
SEAL INTEGRITY



FASTENER FREE

# EnviZion<sup>®</sup> Manual Bonnet

E

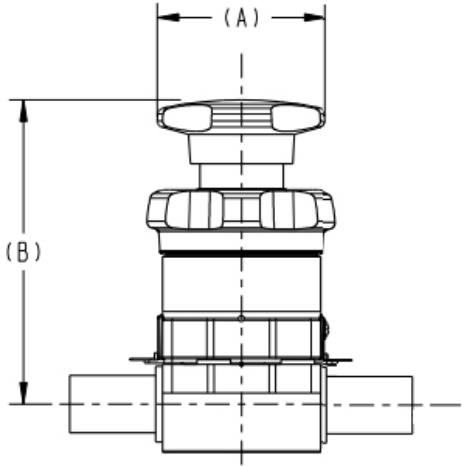

Valve Size		A		B		Bonnet Weight	
Inch	DN	Inch	mm	Inch	mm	Lbs	kg
0.50	15	2.05	52,1	4.04	102,5	1.3	0.6
0.75	20	2.95	74,9	5.30	134,6	3.5	1.6
0.75R	20	2.05	52.1	4.04	102.5	1.3	0.6
1.00	25	2.95	74,9	5.30	134,6	3.5	1.6
1.50	40	3.89	98,8	7.09	180,1	7.3	3.3
2.00	50	3.89	98,8	7.69	195,4	8.5	3.8

## EnviZion Bonnet Guard (EBG) Tamper Resistant / Submersible Option:

- Modified Plunger design maintains "drop in" feature for assembly
- Plunger cover seals & isolates plunger
  - Tool required to remove
- Autoclave capable stainless steel cover with small hex socket
- Umbrella vent seal to avoid pressurization if diaphragm fails
- Sealed hand wheel screw

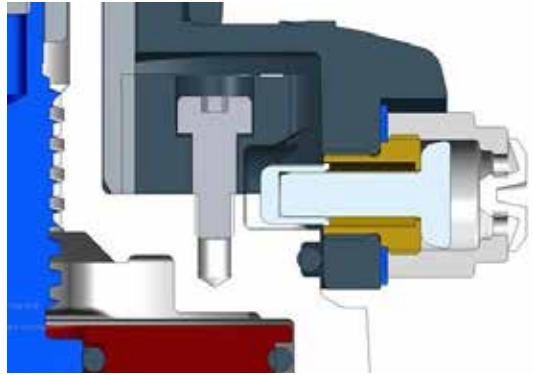

Topworks

# 970 Stainless Steel Manual Bonnet

**P** Resistant to standard washdown protocols, the 970 stainless steel bonnet is the compact, auto-clavable solution for Pharmaceutical/ Bioprocessing applications.

Type: 970

Size Range: 0.5–2" (DN15-DN50)

Max Service Pressure:

0.5–1" (DN15-25): 200 psig (13.8 bar)

1.5–2" (DN40-50): 175 psig (12.1 bar)

Max Service Temperature:

See page D-9

Bonnet Material:

316 Stainless Steel

Handwheel Material:

Glass reinforced polyethersulfone (PES)

FDA compliant to 21CFR 177.1660

Corrosion Resistance:

Resists alcohol, chloride and most caustic wash-downs. For specific chemical resistance, consult factory.

Standard Features:

- Easy assembly and disassembly
- Rising handwheel
- Adjustable travel stop\*
- Visual position indicator
- O-ring splash seal
- Stainless steel stem
- Stainless steel compressor

\* Patent # 6,241,213

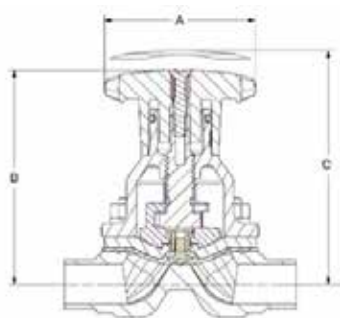

0.5"-1.0"

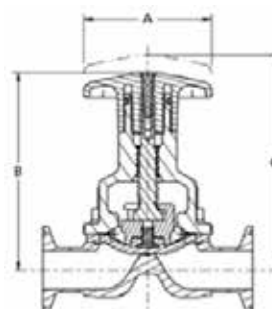

1.5"-2.0"



Valve Size		A		B		C		Bonnet Assembly Weight	
Inch	DN	Inch	mm	Inch	mm	Inch	mm	lb.	kg.
0.5	15	2.51	63,8	2.88	73,2	3.13	79,5	0.59	0,27
0.75	20	2.51	63,8	3.20	81,3	3.58	90,9	0.85	0,39
1	25	2.95	74,9	3.83	97,3	4.33	110,0	1.54	0,70
1.5	40	5.25	133,3	6.05	153,6	6.53	165,9	5.00	2,27
2	50	5.25	133,3	6.05	153,6	6.53	165,9	6.50	2,95

Note: Handwheel diameter and assembly heights are from body centerline to top of bonnet assembly.

<sup>1</sup> Tri Clamp, TC x BW, Short Tangent BW

<sup>2</sup> Extended BW Forging

<sup>3</sup> ISO/DIN

# 963 Manual Bonnet

**P** Capable of withstanding typical washdown media, the 963 bonnet is a fully featured, compact, light-weight, yet rugged design. The 963 is packed with features that fulfill the most demanding requirements of today's critical bioprocessing systems.

Type: 963 & 963S

Size Range: 0.5–4" (DN15-DN100)

Service Pressure/Temperature:

Max Service Pressure:

150 psig (10.34 bar)

Max Service Temperature:

300°F (149°C)

External Temperature Limitations:

300°F (149°C)

Bonnet & Handwheel Material:

Glass reinforced polyethersulfone (PES)

FDA compliant to 21CFR 177.1660

Corrosion Resistance:

Resists alcohol, chloride and most caustic wash-downs.

For specific chemical resistance, consult factory.

Standard Features:

- Autoclavable<sup>1</sup>
- Rising stem
- Adjustable travel stop
- Protective PPS cap
- Brass stem bushing
- Visual position indicator
- Permanent lubrication
- O-ring seals
- Stainless steel compressor
- 0.5 - 4" (DN15-DN100)
- Enclosed fasteners 0.5–3" (DN15–DN80)
- Hygienic internals: 0.5–4" (DN15-DN100)

Optional Features:

- Sealed bonnets: 963S
- Lockable: 0.5, 0.75, 1 in. sizes
- Available in blue, green, & yellow colored hand wheels (sizes 0.5, 0.75, 1, 1.5, 2")

Note: Bonnets manufactured 2010 and beyond with model number 963 and 963S and stainless compressor are autoclavable as standard. Bronze compressor versions are autoclavable only with S2-M2-M17 options.

<sup>1</sup> Steam at 257°F (125°C) for 25 minutes.

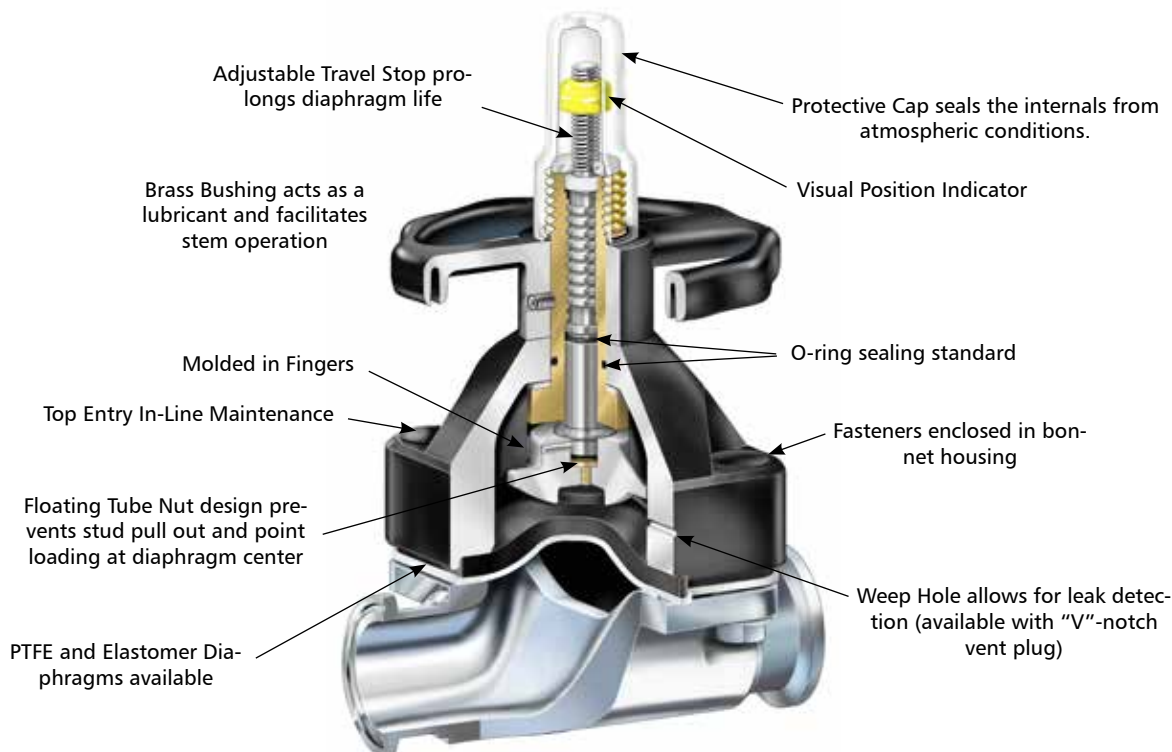

# 963 Manual Bonnet

## **P** Sealed Bonnet Option:

A sealed bonnet provides a secondary containment area for process fluids if the diaphragm should ever fail. A v-notch vent plug is provided to serve as a leak detector and prevents the release of process fluids into the atmosphere. Sealed bonnets are an available option on 963 manual bonnets.

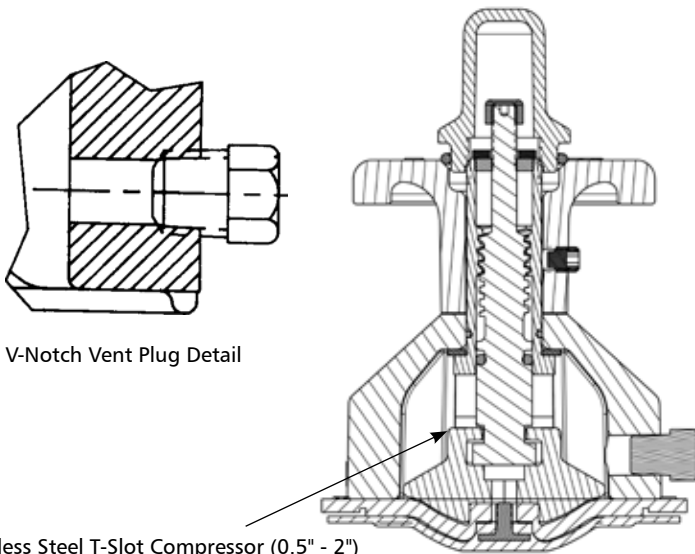

V-Notch Vent Plug Detail

Stainless Steel T-Slot Compressor (0.5" - 2")  
Stainless Steel Pinned Compressor (3" - 4")

Sealed Bonnet - V-Notch Vent Plug

## Colored Hand Wheel Option:

The colored hand wheel option available in blue, green, and yellow will help you organize your operation and maintenance practices to:

- Organize your preventative maintenance work flow
- Segregate your valves by suite or process
- Simplify your work instructions (close the yellow valve)



Topworks

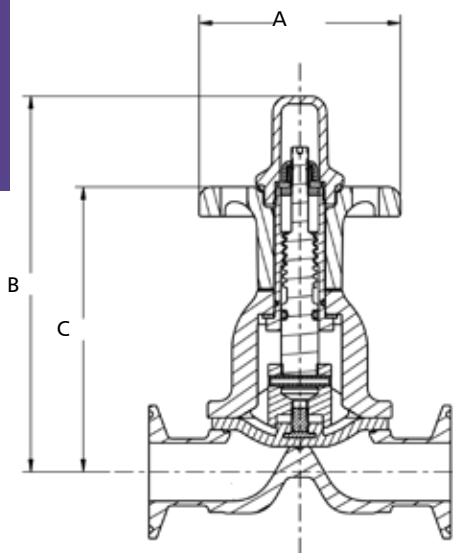

## Weights and Dimensions for 963 Manual Bonnets

Valve Size		A		B		C		Bonnet Weight	
Inch	DN	Inch	mm	Inch	mm	Inch	mm	lb	kg
0.50	15	3.00	76,2	3.62	92,1	2.75	70,0	0.6	0,27
0.75	20	3.00	76,2	4.63	117,5	3.5	88,8	0.9	0,41
1.00	25	3.00	76,2	5.50	139,8	4.17	106,0	1.3	0,59
1.50	40	5.50	139,7	8.30	210,9	5.20	132,3	3.9	1,77
2.00	50	5.50	139,7	8.90	226,2	5.80	147,4	5.3	2,41
2.50 <sup>1</sup>	65	7.75	196,8	11.61	294,9	7.53	191,3	NA	NA
3.00	80	7.75	196,8	11.61	294,9	7.53	191,3	11.7	5,32
4.00	100	10.15	257,8	14.90	378,6	10.24	260,2	16.2	7,36

<sup>1</sup> The 2.5 in. (DN65) valve is a 3 in. (DN80) body and topworks with 2.5 in. (DN65) end connections.

# Bio-Pure<sup>®</sup> Manual Bonnet

**P** The Bio-Pure is the compact solution for the most demanding Biopharm applications. Available in fractional sizes and a wide selection of body materials and end connections the Bio-Pure is the ideal choice for sampling and other low flow, high value processes. Bioreactors, chromatography systems, filtration skids are just a small number of applications that will benefit from the compact, reliable performance. Bio-Pure is capable of withstanding typical Steam in Place (SIP) and Clean in Place (CIP) protocols. For demanding Clean out of Place (COP) requirements the manual BPMC option is the solution for reliable trouble free operation. A standard 2 piece PTFE diaphragm prevents separation of the diaphragm, which is common in laminated diaphragm designs.

## Typical Applications

- Sampling
- Bioreactors
- Chromatography systems
- Filtration skids
- Portable vessels

## Size Range

0.25", 0.31" 0.375", 0.5" (DN 6, 8, 10, 15)

## Service Pressure/Temperature

150 psi at 220°F (10.34 bar at 104°C)

Maximum external temperature: 300°F (149°C)



## Standard Body Materials:

- ASTM A182 Grade 316, DIN 17440. 1.4435
- ASTM A479
- Other materials available upon request

## Bonnet Materials:

- Bonnet: 316 Stainless Steel
- Spindle: Stainless Steel
- Compressor: Stainless Steel
- Handwheel: PES

## Available End Connections:

- 0.5" (DN 15) 16 Gauge
- 0.25", 0.375" (DN 6, 10) 20 Gauge
- DIN/ISO
- Hygienic Tri-Clamp<sup>®</sup>

## Corrosion Resistance:

Resists alcohol, chloride and most caustic washdowns.

## BPM Option

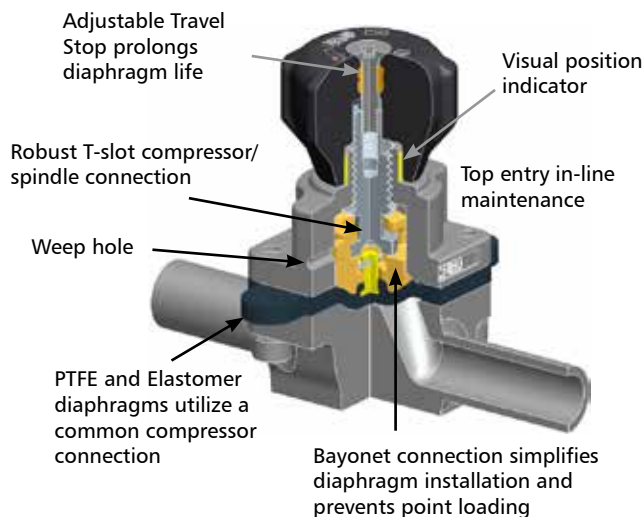

## BPMC Option

BPM features plus

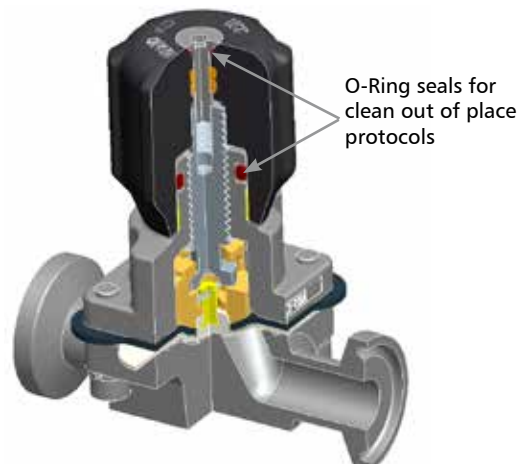

# Bio-Pure® Dimensions

## BPM Option

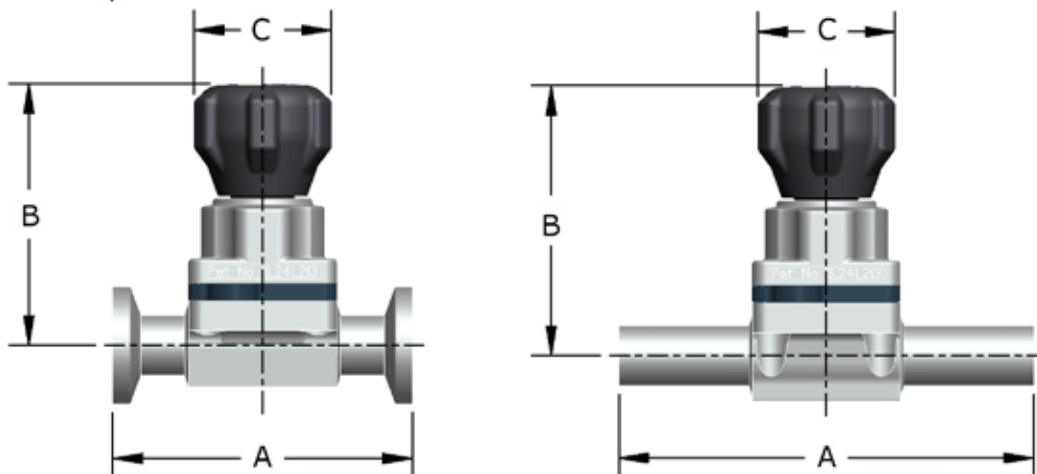

	ANSI (USOD)		DIN/ISO	B Open	C
	A Tri-Clamp	A Butt weld	A		
In.	2.50	3.50	3.50	2.34	1.25
mm	63,5	89,0	89,0	59,4	31,8

## BPMC Option

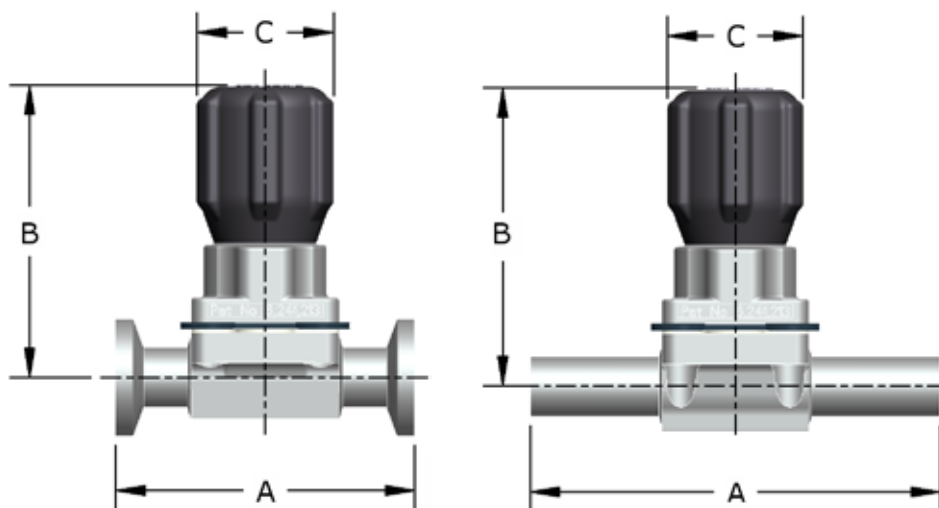

	ANSI (USOD)		DIN/ISO	B Open	C
	A Tri-Clamp	A Butt weld	A		
In.	2.50	3.50	3.50	2.71	1.25
mm	63,5	89,0	89,0	68,9	31,8

# Bio-Tek<sup>®</sup> Manual Bonnet

**P** The Bio-Tek is a compact, lightweight solution ideal for Bioprocessing applications and utilized frequently as a sample or drain port in Pharmaceutical process systems and Pure-Flo fabrications.

Type: 18 & 18S

Size Range: 0.25", 0.375", 0.5"  
(DN6-DN15)

Service Pressure/Temperature:  
150 psi at 220°F (10.34 bar, 104°C)  
Maximum external temperature: 300°F (149°C)

Bonnet Materials:

Model 18

- Bonnet: 316 Stainless Steel
- Spindle: Stainless Steel
- Compressor: Stainless Steel
- Handwheel: PES

Model 18S

- Bonnet: 316 Stainless Steel
- Spindle: Stainless Steel
- Compressor: Stainless Steel
- O-rings: Fluoropolymer, FDA compliant
- Handwheel: PES

Handwheel Material:  
PES (Polyethersulphone)

Standard Features:

- Adjustable travel stop
- Autoclavable

Note: This bonnet is available for Bio-Tek type bodies only.

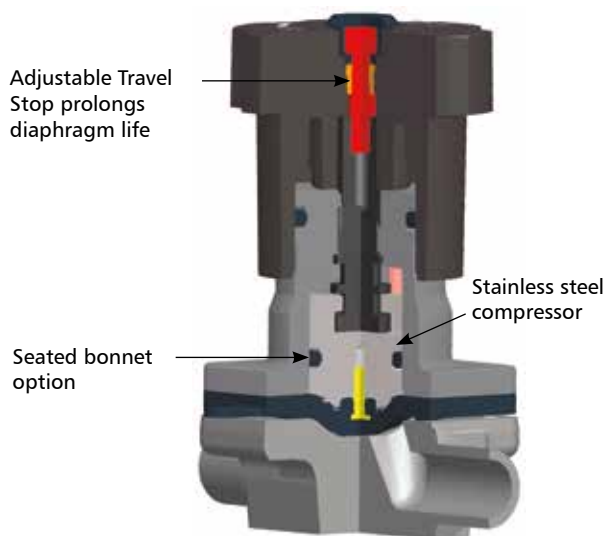

## Dimensions for Bio-Tek Bonnet

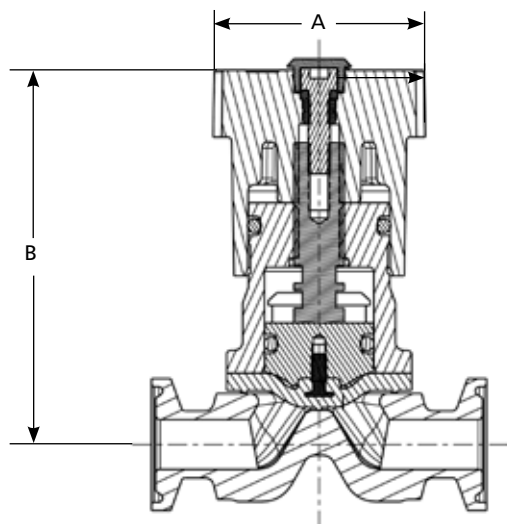

Valve Size		A		B Open	
Inch	DN	Inch	mm	Inch	mm
0.25, 0.375, 0.5	6, 10, 15	1.62	41,2	2.82	71,6

# 913 Stainless Steel Manual Bonnet

**P** Satisfying the most stringent biopharm processing requirements, the 913 is available with many standard and optional features. Stainless steel construction and the availability of a sealed option make the 913 bonnet an excellent choice for critical applications requiring reliability, corrosion resistance and secondary product containment.

Type: 913 & 913S

Size Range: 0.5"–4" (DN15-DN100)

Max Service Pressure:

0.5–1" (DN15-25): 200 psig (13.8 bar)

1.5–2" (DN40-50): 175 psig (12.1 bar)

3–4" (DN80-100): 150 psig (10.3 bar)

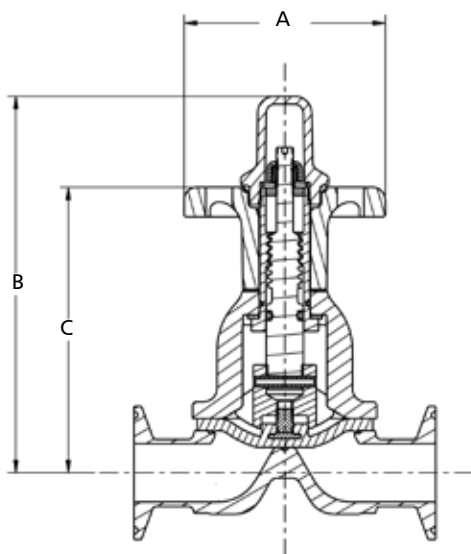

Max Service Temperature:

See Page D-9

Bonnet and Handwheel Material:

Stainless Steel

Corrosion Resistance:

Resists alcohol and most caustic washdowns.

For specific chemical resistance, consult factory.

Standard Features:

- Adjustable travel stop
- Protective cap
- Brass stem bushing
- Visual position indicator
- Permanent lubrication
- O-ring seals
- Bronze compressor
- Hygienic internals



Optional Features:

- Sealed bonnets: 913S
- Adjustable opening stop
- Lockable
- Extended handwheel

Autoclavable Options:

- 913 (Unsealed)
- 913S (Sealed)

Valve Size		A		B		C		Weight	
Inch	DN	Inch	mm	Inch	mm	Inch	mm	lb	kg
0.50	15	3.00	76,2	3.62	92,1	2.75	70,0	0.72	0,33
0.75	20	3.00	76,2	4.63	117,5	3.5	88,8	1.8	0,82
1.00	25	3.00	76,2	5.50	139,8	4.17	106,0	2.3	1,05
1.50	40	5.50	139,7	8.30	210,9	5.20	132,3	7.8	3,55
2.00	50	5.50	139,7	8.90	226,2	5.80	147,4	8.4	3,82
2.50 <sup>1</sup>	65	7.75	196,8	11.61	294,9	7.53	191,3	13.0	5,90
3.00	80	7.75	196,8	11.61	294,9	7.53	191,3	19.0	8,64
4.00	100	10.15	257,8	14.90	378,6	10.24	260,2	32.0	14,55

<sup>1</sup> The 2.5 in. (DN65) valve is a 3 in. (DN80) body and topworks with 2.5 in. (DN65) end connections.

# 903 Cast Iron Bonnet

**P** The 903 is an economical option for applications that do not require autoclavability. A selection of coatings makes the 903 suitable for a range of sanitary service.

Type: 903 & 903S

Size Range: 0.5–4" (DN15–DN100)

Max Service Pressure:

0.5–1": 200 psig (13.8 bar)

1.5–2": 175 psig (12.1 bar)

3–4": 150 psig (10.3 bar)

Max Service Temperature:

See Page D-9

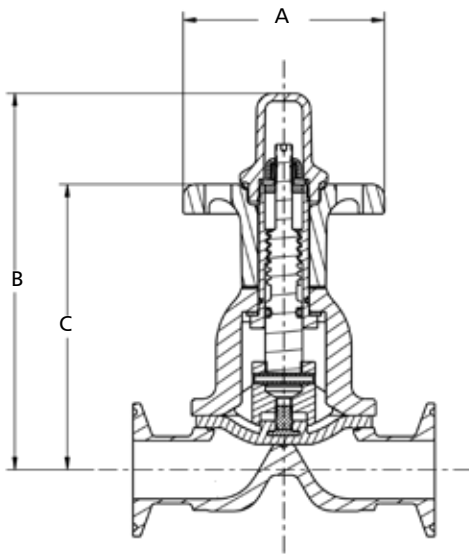

Bonnet Material:

Cast iron with coating

Coatings available: Atmospheric white epoxy and PVDF

Handwheel Material:

Glass reinforced polyarylsulfane (PAS) coated to

match bonnet 0.5–1" (DN15–DN25)

Cast iron with coating 1.5–4" (DN40–DN100)

Corrosion Resistance:

Resists alcohol and most semi-caustic washdowns.

For specific chemical resistance, consult factory.

Standard Features:

- Adjustable travel stop
- Protective cap
- Brass stem bushing
- Visual position indicator
- Permanent lubrication
- O-ring seals
- Cast iron or zinc compressor



Optional Features:

- Sealed bonnets: 903S
- Hygienic internals
- Adjustable opening stop
- Bronze compressor
- Extended handwheel
- Lockable

Valve Size		A		B		C		Weight	
Inch	DN	Inch	mm	Inch	mm	Inch	mm	lb	kg
0.50	15	3.00	76,2	3.62	92,1	2.75	70,0	0.72	0,33
0.75	20	3.00	76,2	4.63	117,5	3.5	88,8	1.8	0,82
1.00	25	3.00	76,2	5.50	139,8	4.17	106,0	2.3	1,05
1.50	40	5.50	139,7	8.30	210,9	5.20	132,3	7.8	3,55
2.00	50	5.50	139,7	8.90	226,2	5.80	147,4	8.4	3,82
2.50 <sup>1</sup>	65	7.75	196,8	11.61	294,9	7.53	191,3	13.0	5,90
3.00	80	7.75	196,8	11.61	294,9	7.53	191,3	19.0	8,64
4.00	100	10.15	257,8	14.90	378,6	10.24	260,2	32.0	14,55

<sup>1</sup> The 2.5 in. (DN65) valve is a 3 in. (DN80) body and topworks with 2.5 in. (DN65) end connections.

# EnviZion<sup>®</sup> Actuator

**E** ITT's breakthrough technology, the EnviZion valve, sets a new standard for the future of hygienic diaphragm valves. The EnviZion valve is designed specifically to help customers install, operate, and maintain their valves more efficiently. This unique design provides a significant reduction in total cost of ownership while supporting the industries' goals to increase productivity, improve reliability and enhance cleanability.

Type: ZA1, ZA2, ZA3, ZA1S (sealed), ZA2S (sealed), ZA3S (sealed)

Size Range: .5-2" (DN15-50)

See sizing charts on page G2 for shutoff pressures

Max Service Temperature: See page D-9

Operating Modes: Fail Closed, Fail Open, Double Acting

Actuator Material: Stainless steel

Bonnet Material: Stainless steel

Corrosion Resistance: Resistant to common industry washdowns. Consult factory for specific chemical resistance

Standard Features:

- Autoclavable
- Thermal compensation system
- Safety lock-pin
- Visual position indication
- Weep hole
- 360 degree air port rotation (excludes .5" (DN15))

Patents can be found at;

[www.engvalves.com/Special-Pages/Pat/](http://www.engvalves.com/Special-Pages/Pat/)



TOOL-LESS  
ASSEMBLY



SEALING SYSTEM  
3RD PARTY  
CERTIFIED



LEAK FREE  
SEAL INTEGRITY



CONTAMINATION  
FREE



ZERO  
RETORQUES



FASTENER FREE

# EnviZion Actuator

E

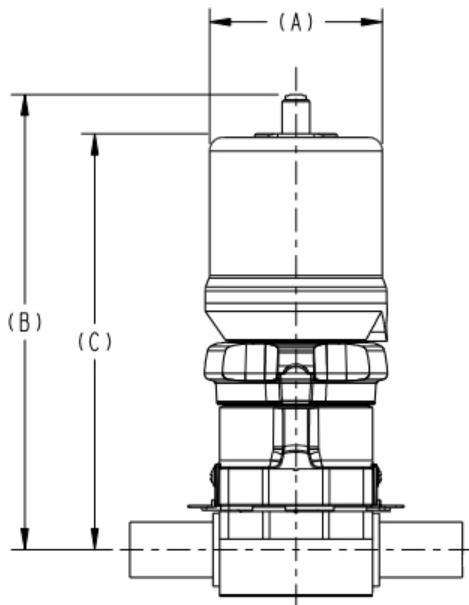

Valve Size		A		B		C		Bonnet Weight	
Inch	DN	Inch	mm	Inch	mm	Inch	mm	Lbs	kg
0.50	15	2.62	66,5	6.56	166,7	6.04	153,4	3.1	1.4
0.75	20	3.12	79,4	8.22	208,7	7.51	190,7	6.2	2.8
0.75R	20	2.62	66.5	6.56	166.7	6.04	153.4	3.1	1.4
1.00	25	3.12	79,4	8.22	208,7	7.51	190,7	6.2	2.8
1.50	40	4.62	117,3	12.08	306,8	11.18	284,0	17.9	8.2
2.00	50	4.62	117,3	12.68	322,1	11.49	291,7	18.5	8.4

## Adjustable Opening Stop:

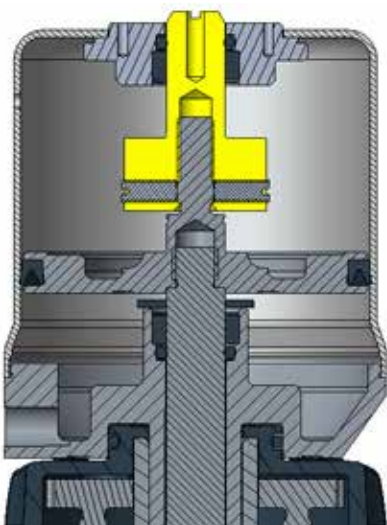

# Advantage<sup>®</sup> 2.1 Actuator

**P** The Advantage 2.1 actuator is the latest evolution in performance of the time-tested Advantage actuator series, the mainstay of the bioprocessing industry for the past 20 years. The Advantage 2.1 has an innovative patent pending compressor attachment method that allows for interchangeability between PTFE and elastomer diaphragms without actuator disassembly.



Type: Diaphragm Actuator  
Size Range: 0.5–2" (DN15–DN50)  
Operating Modes: Fail close, fail open, double acting  
Max Service Pressure: 10.3 bar (150 psig)  
See sizing charts on pages G3–G5 for exact shutoff pressures  
Max Service Temperature: 300°F (150°C)  
Max Actuator Chamber Pressure: 6.2 bar (90 psig)  
Corrosion Resistance: Resists alcohol, chloride and most caustic washdowns  
Autoclavable<sup>1</sup>

<sup>1</sup> Steam at 257°F (125°C) for 25 minutes.

## Diaphragm Compressor Attachment

Advantage 2.1 and ACS feature a modular compressor design for quick changeover between PTFE and elastomer diaphragms. No actuator disassembly is required for diaphragm type changes. The modular design is compatible with all Pure-Flo diaphragm types.

The modular compressor design features a stainless steel compressor and tube. The key to the modular system is a robust stainless steel tube nut that allows compressor float, ensuring even distribution of actuation closing forces. This concept minimizes diaphragm point loading. Diaphragm change over kits will be available.

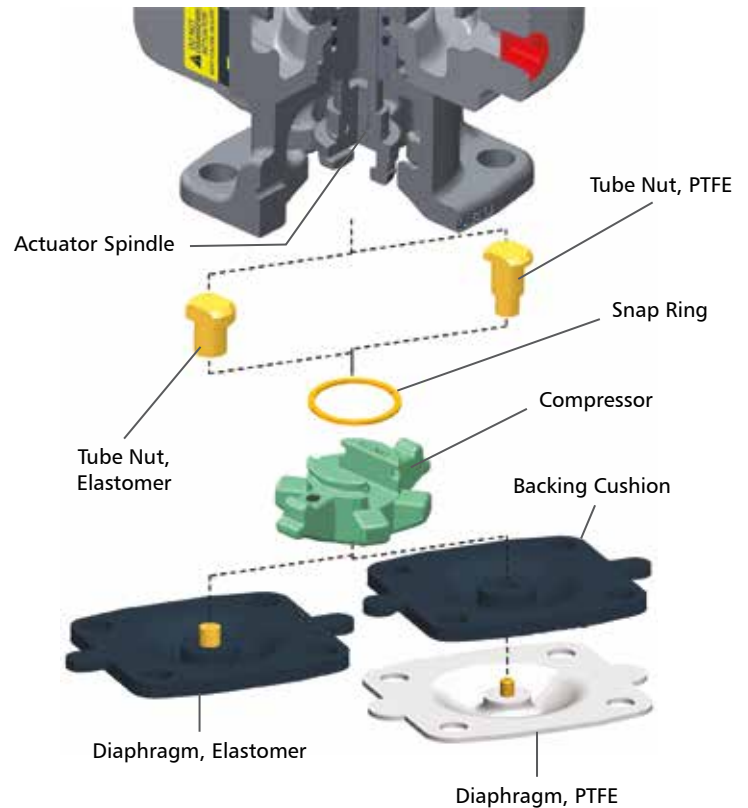
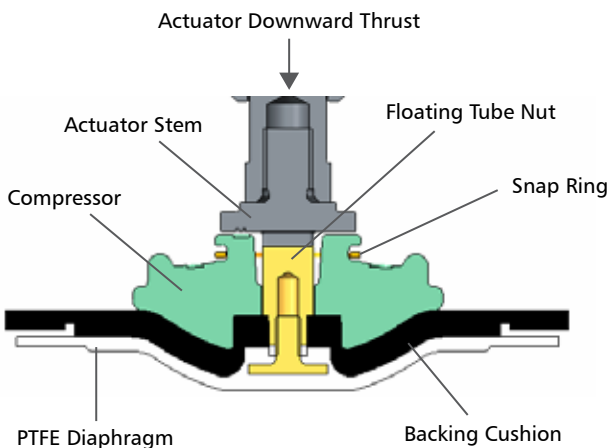

Note: Patent Pending Compressor Design

# Advantage<sup>®</sup> 2.1 Weights & Dimensions

## Dimensions

Valve Size		A Valve Open		C		D	
Inch	DN	in	mm	in	mm	in	mm
0.25	6	4.31	109,5				
0.38	10	4.31	109,5				
0.50	15	4.31	109,5				
0.50	15	4.87	123,7	3.34	85	3.00	76
0.75	20	6.06	153,9	4.56	116	3.88	98
1.00	25	6.56	166,6	4.56	116	3.88	98
1.50	40	10.42	264,7	6.41	163	5.94	151
2.00	50	11.16	283,5	6.41	163	5.94	151

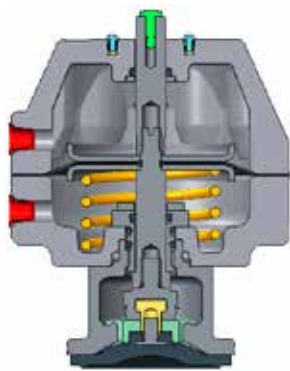

Fail Open  
(Spring-to-Open, Air-to-Close)

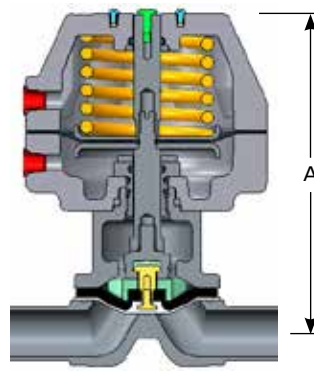

Fail Close  
(Air-to-Open, Spring-to-Close)

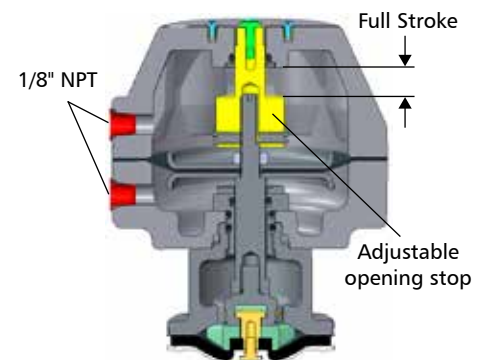

Optional Adjustable Opening Stop  
(AOS)

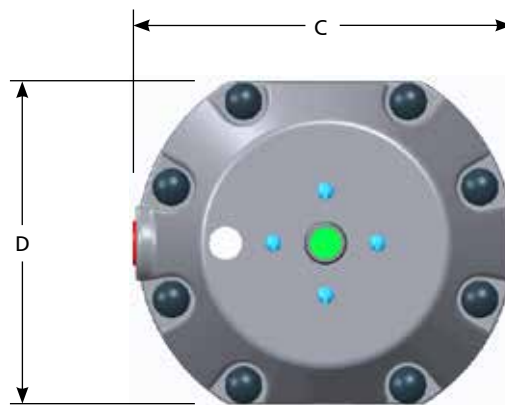

## Actuator Weights (Less Body)

Valve Size		Double Acting		Fail Open		Fail Close	
Inch	DN	Lbs.	Kg.	Lbs.	Kg.	Lbs.	Kg.
0.50	15	2.00	0,91	2.09	0,95	2.34	1,06
0.75	20	3.69	1,67	3.78	1,71	4.34	1,97
1.00	25	4.47	2,03	4.59	2,08	5.16	2,34
1.50	40	12.10	5,49	12.60	5,71	16.44	7,46
2.00	50	15.16	6,88	15.66	7,10	19.50	8,84

# Advantage<sup>®</sup> Compact Stainless (ACS)

**P** The Advantage<sup>®</sup> Compact Stainless (ACS) is the latest addition to the process proven Advantage Actuator product line. Designed as a maintenance-free actuator, it is engineered to handle the most demanding requirements of the bioprocessing and pharmaceutical industries. The stainless steel construction of the ACS is suited for severe duty applications, such as SIP and high-cycle applications. It has been subjected to extensive life-cycle testing that far exceeds industry requirements.

The compact size of the ACS provides the utmost in design flexibility. It allows for space-saving system designs, further minimizing holdup volumes that are critical to increasing efficiency and saving time and money. Engineering improvements in the ACS offer a cost-effective alternative for clean-room use, lab environments and other critical applications. With a stainless steel exterior, the ACS is perfect for clean-room applications requiring both aesthetics and washdown compatibility.

All of this makes the ACS a versatile, feature-packed, cost-effective option for the demanding biopharm and food & beverage industries.



Type: Piston Actuator  
Size Range: 0.25–2" (DN6–DN50) (Bio-Pure size)  
Operating Modes: Fail close, fail open, double acting  
Max Service Pressure: 10.3 bar (150 psig)  
See sizing charts on pages G6–G8 for exact shutoff pressures  
Max Service Temperature: 300°F (150°C)  
Max Autoclave Temperature: 273°F (134°C)  
Max Actuator Chamber Pressure: 6.2 bar (90 psig)  
Corrosion Resistance: Resists alcohol, chloride and most caustic washdowns

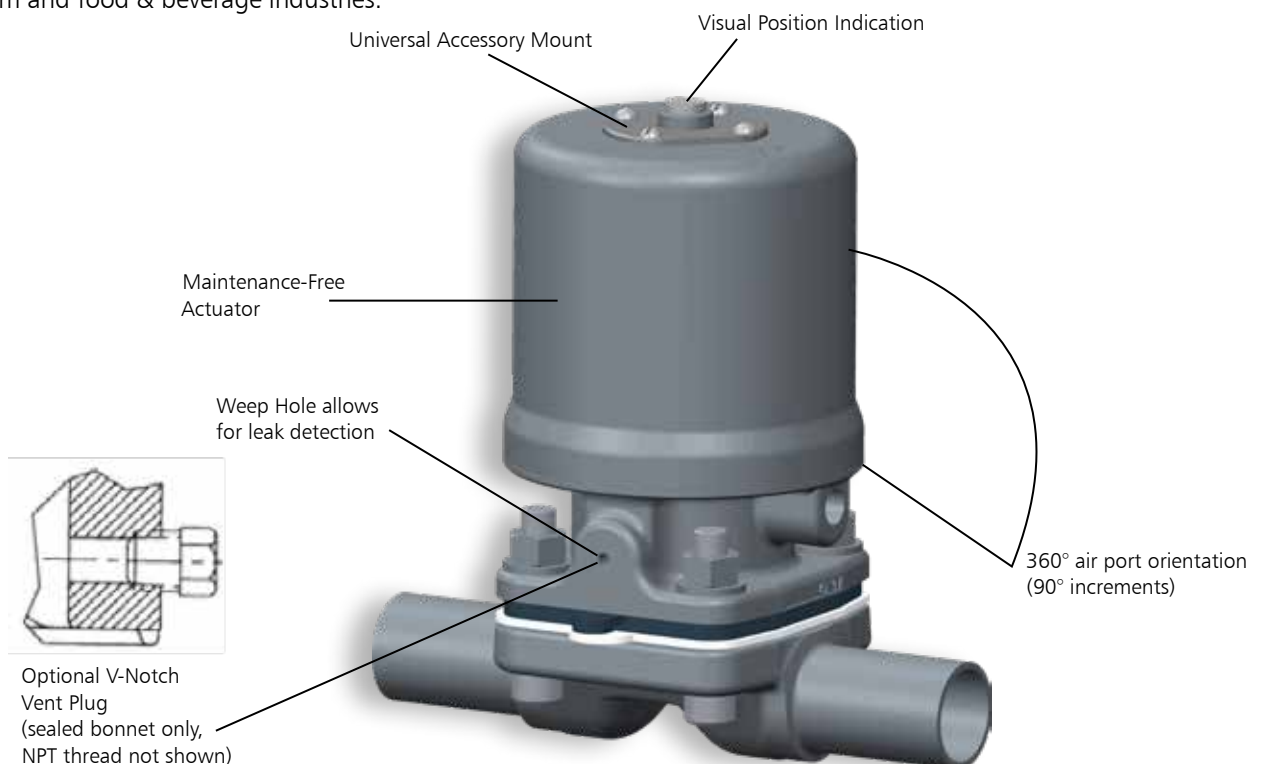

# ACS Weights & Dimensions

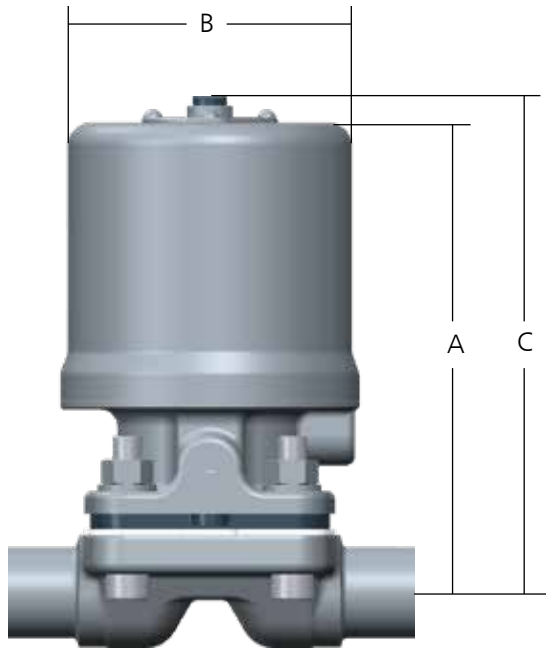

## Dimensions with Forged Body & Weights (less body)

Valve Size		A		B		C		Actuator Weight (less body)					
Inch	DN	in	mm	in	mm	in	mm	Fail Close		Fail Open		Double Acting	
								Lbs.	Kg	Lbs.	Kg	Lbs.	Kg
BP	BP	3.48	88,4	1.75	44,5	3.83	97,3	1.2	0,55	1.2	0,55	1.2	0,55
0.50	15	4.07	103,4	2.62	66,5	4.42	112,3	2.4	1,1	2.1	1,0	2.3	1,0
0.75	20	4.91	124,7	3.12	79,2	5.51	140,0	3.5	1,6	3.0	1,4	3.3	1,5
1.00	25	5.16	131,1	3.12	79,2	5.89	149,6	4.0	1,8	3.1	1,4	3.4	1,5
1.50	40	8.80	223,5	4.62	117,3	9.78	248,4	14.3	6,5	10.3	4,6	10.9	4,9
2.00	50	9.22	234,2	4.62	117,3	10.51	267,0	17.1	7,8	13.3	6,0	14.3	6,5

# Series 33 Advantage<sup>®</sup> Actuator

**P** The Series 33 Advantage Actuators extend the size range of the Advantage Actuator product line to 3" and 4" valves. The Series 33 Advantage Actuators have been introduced to further reduce the dimensional envelope and weight for installations in the Pharmaceutical/ Bioprocessing industries. The Series 33 4" Spring to Close actuator is 25% smaller in diameter, has 22% reduction in height and offers a 32% reduction in weight than a comparable 4" Series 47 actuator.

Type: Series 33 Advantage Actuator

Size Range: 3–4" (DN80–DN100)

Operating Modes:

Fail Close\*, Fail Open, Double Acting

Max Service Pressure/Temperature:

150 psig (10.34 bar)

300°F (149°C)

External Temperature Limitations:

150°F (66°C)

Actuator Cover Material:  
Polyester Thermoset

Bonnet Material:  
Nylon coated ductile iron  
(4 inch); Stainless Steel (3 inch)



Corrosion Resistance:  
Resists alcohol, chloride and most caustic washdowns.  
For specific chemical resistance, consult factory.

Standard Features:

- Visual position indicator
- O-ring seals
- Switch mounting bolt pattern

Optional Features:

- Hygienic internals
- Solenoids available

\*Springs self-contained (Fail close only)

Note: See page G-3 - G-5 for actuator sizing.

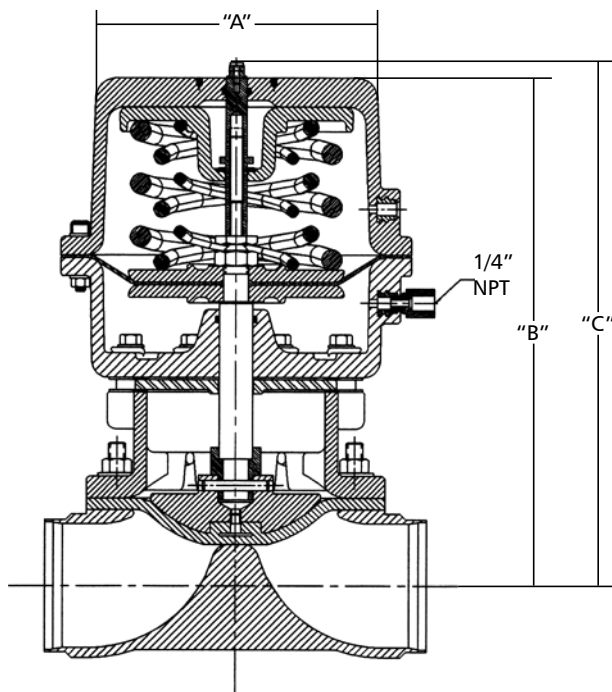

## Dimensions & Actuator Weights (less body)

Valve Size		A		B		C		Double Acting		Fail Open		Fail Close			
Inch	DN	Inch	mm	Inch	mm	Inch	mm	Lbs.	Kg.	Lbs.	Kg.	60#		90#	
												Lbs.	Kg.	Lbs.	Kg.
3.00	80	7.95	201,9	14.2	360,7	16.41	416,8	39.00	17,69	42.30	19,19	54.20	24,59	58.00	26,31
4.00	100	7.95	201,9	15.82	401,8	18.00	452,2	44.00	19,96	47.30	21,46	59.20	26,85	63.00	28,58

# Series 47 Advantage<sup>®</sup> Actuator

**P** The Series 47 Advantage Actuators extend the size range of the Advantage Actuator product line to 3" and 4" valves. Similar to the smaller valve sized Advantage Actuators, the 3–4" series 47 (DN80–DN100) actuator is also diaphragm driven, o-ring furnished and available in three modes of operation. The actuator design features the same dimensional envelope regardless of operation mode.

Type: Series 47 Advantage Actuator  
 Size Range: 3–4" (DN80–DN100)  
 Operating Modes:  
 Fail Close\*, Fail Open, Double Acting  
 Max Service Pressure/Temperature:  
 150 psig (10.34 bar)  
 300°F (149°C)  
 External Temperature Limitations:  
 150°F (66°C)

Actuator Cover Material:  
 Polyester Thermoset  
 Bonnet Material:  
 Nylon coated ductile iron

Corrosion Resistance:  
 Resists alcohol, chloride and most caustic washdowns.  
 For specific chemical resistance, consult factory.



- Standard Features:
- Visual position indicator
  - O-ring seals
  - Adjustable Opening Stop (AOS)
  - Adjustable Travel Stop (ATS)
  - Switch mounting bolt pattern

- Optional Features:
- Hygienic internals
  - Solenoids available

\*Springs self-contained (Fail close only)  
 Note: See page G3-G-5 for actuator sizing.

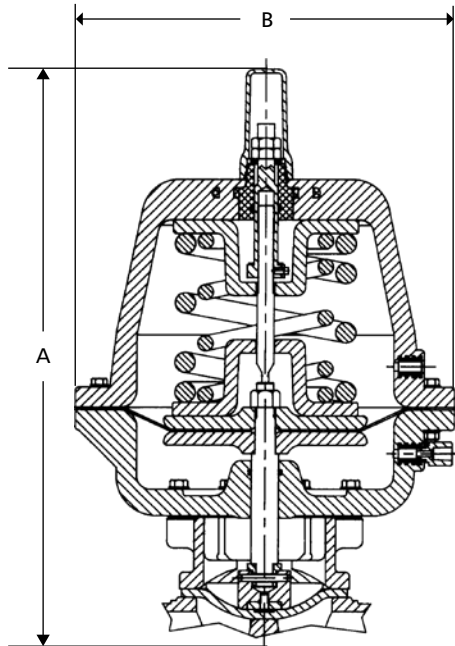

Reverse Acting

## Dimensions & Actuator Weights (less body)

Valve Size		Double Acting		Fail Open		Fail Close			
Inch	DN	lbs.	Kg.	lbs.	Kg.	60#		80#	
						lbs.	Kg.	lbs.	Kg.
3.00	80	58	26,4	61	27,9	85	38,7	93	42,0
4.00	100	63	28,5	66	29,9	90	40,7	97	44,0

# Dia-Flo<sup>®</sup> Actuator

**P** The Dia-Flo actuator, diaphragm driven and pneumatically operated, is a process proven actuator suitable for both the Pure-Flo and Dia-Flo product lines. The Dia-Flo actuator is recommended as an alternative to the Advantage Actuator for applications in which the line pressure or available plant air pressure is not within the advantage actuator parameters.

Type: Dia-Flo

Size Range:

Available in seven interchangeable sizes and can be readily mounted to any size valve with the proper size bonnet. See Dia-Flo catalog DV for actuator sizing

Actuator Materials:

Aluminum

Ductile iron - optional

Corrosion Resistant Coatings:

White epoxy

PVDF

Nylon

Bonnet Materials:

Ductile iron

Stainless steel – optional

Actuator Air Pressure:

5.9 bar (85 psi) max

Options:

- Adjustable opening stop
- Adjustable travel stop<sup>1</sup>
- Hygienic internals
- Visual position indicator
- Wrench or handwheel operated
- Manual overrides
- Solenoids available

<sup>1</sup>Adjustable travel stop is standard on all fail close actuators (except 3212)

## Dualrange<sup>®</sup> Control Valve

The Dualrange control valve is the first diaphragm valve designed expressly for control work. Available in 1–6" sizes, it combines all the advantages of ITT weir-type diaphragm valves with greatly improved throttling characteristics. The Dualrange utilizes the Dia-Flo actuator and has greater rangeability than other diaphragm valves, due to the dual nested compressors unique to Pure-Flo. Refer to the Dia-Flo catalog DV at [www.engvalves.com](http://www.engvalves.com) for more information.



ITT is a world leader in the design and manufacture of aseptic diaphragm valves. We also strive to offer our customers the latest technology for the networking, monitoring and control of these valves. Whether it be as simple as on/off switch or a more complicated positioner or networked feedback device, we can supply our customer's needs for a complete automated valve with precise control requirements.

Our accessories are simple to mount and set, and are compact enough to be easily installed and maintained where space is at a premium.

Many of our accessories have been installed in other industries such as oil and petrochemical, chemical, pulp and paper, mining and power plants across the world, as well as in less demanding environments.

Our accessory portfolio includes our VSP and VSP+ switch devices as well as our positioners.

While ITT strives for "One Valve – One Source – One Solution" for our customers' valve needs, we recognize that we may need to offer alternative solutions for their valve controls. We continue to utilize the latest emerging technologies in our product offerings. Along with our dedicated and experienced engineering staff, we can combine our own products with those of 3rd party suppliers to provide the customer with the best and most economical solution for their particular needs.

Providing a valve to fit your application and not your application to fit our valve; this is what ITT is all about.

## Table of Contents

Value Switch Package VSP, VSP+ . . . . .	F2-3
73 Series Positioner . . . . .	F6
TMP-3000 Positioner . . . . .	F7



# Valve Switch Package (VSP, VSP+)



The VSP and now the VSP+ switch package is engineered with cost effectiveness, simplicity and flexibility in mind. The VSP and VSP+ models maintain the same small dimensional envelope that is critical when space is at a premium. The VSP+ switch options expand on the VSP package capabilities and options. The plus (+) options provide added benefits of self calibrating open/closed positions in combination with high visibility LED illumination. The VSP and VSP+ switch packages are a perfect complement to all Pure-Flo Advantage actuators.



## Specifications

	US	Metric
Size Range	0.25-2" , 2.5-4" (VSP on 33 series actuators only)	DN6-DN50, (DN 65 - DN 100 33 Series actuators only)
Temperature	140°F	60°C
Switch Selection	Mechanical and Proximity (see chart)	
Housing Material	Polyamide, FDA compliant	
Cover Material	Polysulfone, FDA compliant	
Wire Gauge	12 Gauge max. input	
Conduit Port	One M20 conduit port, located radially at any position, 360° (1/2"-NPT adapter available)	
Enclosure Rating	Nema: Nema 4X Ingress Protection Rating: IP66	
Switch Certifications	VSPN & VSP+N: CE, cCSAus, FM, ATEX, IECEx VSP & VSP+P Sensor: CE, cULus VSPZ: CE, cULus VSPS48, VSPG30, VSP+S, & VSP+G: cULus Terminal Strip: CE, cULus	
Hazardous Ratings for VSPN & VSP+N with Approved Amplifier/Barrier	Intrinsically Safe - FM, ATEX, IECEx, cCSAus approved Group II, category 2D T6 / 2G T6 Class I, II & III, Division 1, Groups A-G T6 Entity Parameters: Vmax=15V, Imax=50mA, Pmax=120mW, Ci=160nF, Li=220μH	

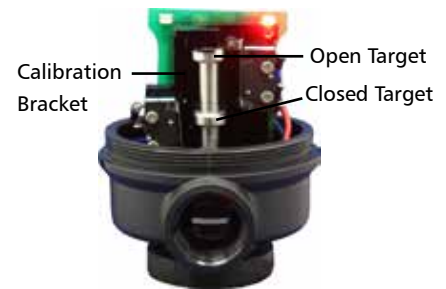

Note: VSP and VSP+ are not autoclavable. LEDs not available for Namur switch offering on the VSP+

## VSP+ Self Calibration System

The VSP+ models feature a robust self calibration system that simplifies the switch setting process. The self calibration system features unique energized Open / Closed targets that adjust to the travel limits of the actuator. Calibration can be completed in seconds without any requirement for tools. Reducing the need for specially trained personnel. Countless maintenance hours can be saved and nuisance alarms eliminated.

## VSP+ High Intensity LEDs

The VSP+ option features high intensity LEDs for outstanding 360 degree visual indication. An additional power LED assists in troubleshooting.

# Value Switch Package (VSP, VSP+)

## Basic VSP

Order Code	Switch Type	Switch Contact/ Output	Amperage	Voltage	Auto Calibration	High Visibility LED
VSPG30	Mechanical	Gold SPDT	100 mA	30VAC/DC	N/A	N/A
VSPS48	Mechanical	Silver SPDT	6A	48VAC/DC	N/A	N/A
VSPS240	Mechanical	Silver SPDT	10A	240VAC	N/A	N/A
VSPN	Proximity	2 Wire Namur	30 mA	30VDC	N/A	N/A
VSPN	Proximity	3 Wire PNP	200 mA	30VDC	N/A	N/A
VSPZ	Proximity	2 Wire "Z"	200 mA	36VDC	N/A	N/A

## VSP+

Order Code	Switch Type	Switch Contact/ Output	Amperage	Voltage	Auto Calibration	High Visibility LED
VSP+G	Mechanical	Gold SPDT	100 mA	24VDC	x	x
VSP+S	Mechanical	Silver SPDT	1A	24VDC	x	x
VSP+N	Proximity	2 Wire Namur	50 mA	15VDC	x	N/A
VSP+P	Proximity	3 Wire PNP	200 mA	24VDC	x	x



Mechanical

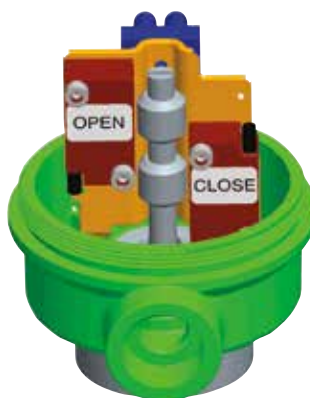

Proximity



VSP for >2.5" - 4" 33 Series actuator applications

## Dimensions

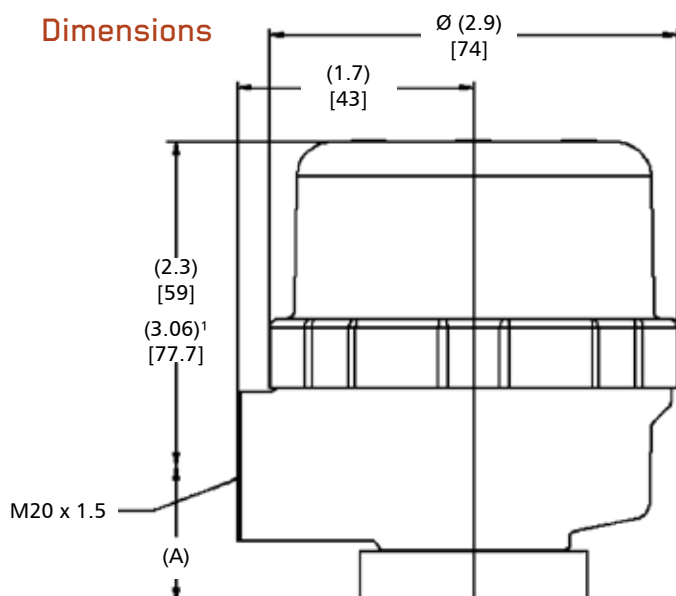

Valve Size	A	
	in	mm
BT	1.00	25.4
0.5	1.00	25.4
0.75	1.00	25.4
1	1.00	25.4
1.5	1.50	38.1
2	1.50	38.1
2.5	2.07	52.6
3	2.07	52.6
4	2.07	52.6

<sup>1</sup> 2.5-4" 33 Series actuators

# 73 Series Positioner

**P** For throttling and flow control applications, the direct mounted 73 Series Positioner mounted on an Advantage 2.1, Series 33 or Series 47 actuator is a compact and reliable solution.

## Features:

- Pneumatic 73-series positioner
- Operates on 3-15 psi (0.2-1.0 bar)
- A transducer can be adapted to handle an I/P conversion from a typical 4-20 mA
- Close-coupled design allows for direct air loading from the positioner to the upper actuator chamber in Air to Open - Air to Close and Fail Open actuators
- The transparent tubing allows for visual position verification

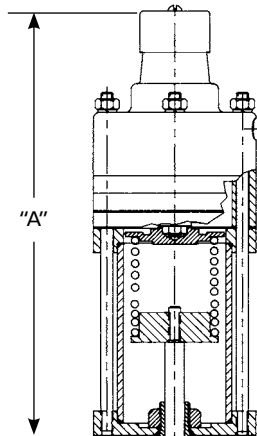

Valve Size		A	
Inch	DN	Inch	cm
0.75	20	8.34	212
1.00	25	8.34	212
1.50	40	9.06	230
2.00	50	9.06	230
3.00	80	9.81	249
4.00	100	9.81	249

# TMP-3000 Positioner

A compact and easy to use solution for throttling and flow control applications. The TMP 3000 features digital programming and easy to run auto calibration. The TMP 3000 features an integral I/P converter and two choices of flow rates for the most demanding of applications.

Item - Type	TMP -3000
Power Supply	24VDC $\pm$ 10%
Input Signal	0/4...20mA, 0...5/10V Do not exceed 10V max*
Residual Ripple	10%, Not industrial DC
Power Consumption	< 4W
Output	4 ~ 20mA
Output Characteristics	Linea, EQ%, Quick Open user set (16 point)
Operating Temp	-10 ~ 60 °C
Supply Pressure	0 ~ 0.7 MPa (0 ~ 7 bar)
Air Consumption	0 LPM
Flow Capacity	20 / 50 LPM
Filtering Size	5 micron
Acting Type	Single 2 solenoid valves Double 4 solenoid valves
Stroke	5 ~ 40mm
Air Connection	G1/8 ( $\varnothing$ 6mm tube)
Conduit	M16x1.5 (with screw terminals)
Ingress Protection	IP67
Body Material	PPS
Cover Material	PC
Weight	820g (1.8lb)

\* Voltage for input signal in excess of 10V may cause irreparable damage to positioner unit

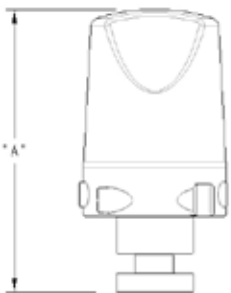

Valve Size	A (inch)	A (cm)
0.5	7.45	19
0.75	7.45	19
1	7.45	19
1.5	7.82	20
2	7.82	20
33 Series	10.63	27
47 Series	TBD	TBD



### Table of Contents

Actuator Sizing .....	G2-9
Valve stroke .....	G9
Flow coefficients .....	G10-11
Validation and qualification .....	G12
Compliance .....	G13-14
Approvals .....	G15-20



# EnviZion® Actuator

## E EnviZion Actuator Sizing

Valve Size	BioviZion		0.5" (DN 15)		0.75" (DN 20)		0.75"R (DN 20)		1" (DN 25)		1.5" (DN 40)		2.0" (DN 50)	
ΔP	100%	0%	100%	0%	100%	0%	100%	0%	100%	0%	100%	0%	100%	0%
Actuator Model	Fail Closed - Reverse Acting - Spring to Close Maximum Line Pressure (psi/(bar))													
ZA2/ZA2S	150 (10.3)	150 (10.3)	150 (10.3)	135 (9.3)	150 (10.3)	70 (4.8)	150 (10.3)	135 (9.3)	150 (10.3)	70 (4.8)	150 (10.3)	90 (6.2)	130 (9.0)	65 (4.5)
ZA26/ZA26S (60#)	65 (4.5)	58 (4.0)	150 (10.3)	83 (5.7)			150 (10.3)	83 (5.7)						
ZB2/ZB2S					135 (9.3)	80 (5.5)			135 (9.3)	80 (5.5)	150 (10.3)	104 (7.2)	150 (10.3)	87 (6.0)
ZB26/ZB26S (60#)					30 (2.1)	30 (2.1)			30 (2.1)	30 (2.1)	52 (3.6)	52 (3.6)	57 (3.9)	30 (2.1)

Valve Size	BioviZion		0.5" (DN 15)		0.75" (DN 20)		0.75"R (DN 20)		1" (DN 25)		1.5" (DN 40)		2.0" (DN 50)		
ΔP	100%	0%	100%	0%	100%	0%	100%	0%	100%	0%	100%	0%	100%	0%	
Actuator Model	Line Pressure	Fail Open - Direct Acting - Spring to Open Air pressure required to shut-off line pressure (psi/(bar))													
ZA1/ZA1S	20	67 (4.6)	67 (4.6)	45 (3.1)	45 (3.1)	45 (3.1)	45 (3.1)	45 (3.1)	45 (3.1)	45 (3.1)	66 (4.6)	66 (4.6)	78 (5.4)	80 (5.5)	
ZA1/ZA1S	40	69 (4.8)	69 (4.7)	48 (3.3)	50 (3.4)	50 (3.4)	53 (3.7)	48 (3.3)	50 (3.4)	53 (3.7)	70 (4.8)	72 (5.0)	82 (5.7)	90 (6.2)	
ZA1/ZA1S	60	72 (5.0)	72 (5.0)	51 (3.5)	54 (3.7)	54 (3.7)	62 (4.3)	51 (3.5)	54 (3.7)	62 (4.3)	73 (5.0)	79 (5.4)	86 (5.9)	100 (6.9)	
ZA1/ZA1S	80	74 (5.1)	74 (5.1)	54 (3.7)	59 (4.1)	59 (4.1)	70 (4.8)	54 (3.7)	59 (4.1)	70 (4.8)	76 (5.2)	85 (5.9)	90 (6.2)		
ZA1/ZA1S	100	76 (5.2)	77 (5.3)	57 (3.9)	63 (4.3)	63 (4.3)	79 (5.4)	57 (3.9)	63 (4.3)	79 (5.4)	79 (5.4)	91 (6.3)	95 (6.5)		
ZA1/ZA1S	125	79 (5.4)	81 (5.6)	61 (4.2)	69 (4.8)	69 (4.8)	89 (6.1)	61 (4.2)	69 (4.8)	89 (6.1)	83 (5.7)	99 (6.8)	100 (6.9)		
ZA1/ZA1S	150	82 (5.7)	84 (5.8)	65 (4.5)	75 (5.2)	75 (5.2)	100 (6.9)	65 (4.5)	75 (5.2)	100 (6.9)	87 (6.0)				
ZB1/ZB1S	20					44 (3.0)	44 (3.0)			44 (3.0)	44 (3.0)	39 (2.7)	39 (2.7)	41 (2.8)	
ZB1/ZB1S	40					47 (3.2)	48 (3.3)			47 (3.2)	48 (3.3)	42 (2.9)	44 (3.0)	48 (3.3)	
ZB1/ZB1S	60					50 (3.4)	56 (3.9)			50 (3.4)	56 (3.9)	45 (3.1)	51 (3.5)	55 (3.8)	
ZB1/ZB1S	80					53 (3.7)	64 (4.4)			53 (3.7)	64 (4.4)	49 (3.4)	58 (4.0)	62 (4.3)	
ZB1/ZB1S	100					56 (3.9)	73 (5.0)			56 (3.9)	73 (5.0)	52 (3.6)	65 (4.5)	69 (4.8)	
ZB1/ZB1S	125					59 (4.1)	83 (5.7)			59 (4.1)	83 (5.7)	56 (3.9)	74 (5.1)	77 (5.3)	
ZB1/ZB1S	150					63 (4.3)				63 (4.3)		60 (4.1)	83 (5.7)	88 (6.1)	
Actuator Model	Line Pressure	Double Acting - Air to Open Air to Close Air pressure required to shut-off line pressure (psi/(bar))													
ZA3/ZA3S	20	43 (3.0)	43 (3.0)	30 (2.1)	17 (1.2)	30 (2.1)	30 (2.1)	30 (2.1)	30 (2.1)	30 (2.1)	30 (2.1)	17 (1.2)	18 (1.2)	27 (1.9)	
ZA3/ZA3S	40	45 (3.1)	45 (3.1)	33 (2.3)	22 (1.5)	35 (2.4)	38 (2.6)	33 (2.3)	35 (2.4)	35 (2.4)	38 (2.6)	20 (1.4)	26 (1.8)	31 (2.1)	
ZA3/ZA3S	60	48 (3.3)	48 (3.3)	36 (2.5)	27 (1.9)	39 (2.7)	47 (3.2)	36 (2.5)	39 (2.7)	39 (2.7)	47 (3.2)	23 (1.6)	35 (2.4)	34 (2.3)	
ZA3/ZA3S	80	50 (3.4)	50 (3.4)	39 (2.7)	32 (2.2)	44 (3.0)	55 (3.8)	39 (2.7)	44 (3.0)	44 (3.0)	55 (3.8)	27 (1.9)	43 (3.0)	38 (2.6)	
ZA3/ZA3S	100	52 (3.6)	52 (3.6)	42 (2.9)	37 (2.5)	48 (3.3)	64 (4.4)	42 (2.9)	48 (3.3)	48 (3.3)	64 (4.4)	30 (2.1)	51 (3.5)	41 (2.8)	
ZA3/ZA3S	125	55 (3.8)	56 (3.9)	46 (3.2)	43 (3.0)	54 (3.7)	74 (5.1)	46 (3.2)	54 (3.7)	54 (3.7)	74 (5.1)	34 (2.3)	62 (4.3)	46 (3.1)	
ZA3/ZA3S	150	58 (4.0)	60 (4.1)	50 (3.4)	49 (3.4)	60 (4.1)	85 (5.9)	50 (3.4)	60 (4.1)	60 (4.1)	85 (5.9)	38 (2.6)	72 (5.0)	50 (3.4)	
ZB3/ZB3S	20					34 (2.3)	39 (2.7)			34 (2.3)	39 (2.7)	26 (1.8)	26 (1.8)	30 (2.1)	
ZB3/ZB3S	40					37 (2.6)	48 (3.3)			37 (2.6)	48 (3.3)	30 (2.1)	32 (2.2)	37 (2.6)	
ZB3/ZB3S	60					40 (2.8)	57 (3.9)			40 (2.8)	57 (3.9)	34 (2.3)	40 (2.8)	44 (3.0)	
ZB3/ZB3S	80					44 (3.0)	65 (4.5)			44 (3.0)	65 (4.5)	38 (2.6)	47 (3.2)	51 (3.5)	
ZB3/ZB3S	100					47 (3.2)	75 (5.2)			47 (3.2)	75 (5.2)	41 (2.8)	55 (3.8)	58 (4.0)	
ZB3/ZB3S	125					51 (3.5)	86 (5.9)			51 (3.5)	86 (5.9)	46 (3.1)	64 (4.4)	66 (4.6)	
ZB3/ZB3S	150					55 (3.8)				55 (3.8)		51 (3.5)	73 (5.0)	75 (5.2)	

Note: Fail closed actuators require 90 psi (6 bar) instrument air to achieve full open with 0 psi/bar line pressure (except ZA26 and ZB26 which require 60 psi (4 bar) to open). The exposure of PTFE diaphragms to steam may reduce shutoff capabilities or increase air required to shut off by as much as 30%.

# Advantage<sup>®</sup> 2.1, Series 33, Series 47 Actuator Sizing - Fail Close



Fail Close Actuators - Air-To-Open, Spring-To-Close (Reverse Acting)																		
	Actuator and Spring Package	Maximum Line Pressure (psig)															Air pressure required to open for full stroke at 0 psi line pressure	
		Valve Size																
		100 % ΔP							0% ΔP									
	BT <sup>2</sup>	0.5"	0.75"	1"	1.5"	2"	3"	4"	BT <sup>2</sup>	0.5"	0.75"	1"	1.5"	2"	3"	4"		
Elastomer Diaphragm	A203/B203 60#	150							150								55	
	A204/B204 90#	150							150								75	
	A205/B205 60#		110							90							50	
	A206/B206 90#		150							150							90	
	A208/B208 60#			100							60						45	
	A208/B208 60#				70							40					60	
	A209/B209 90#			150	150							120	85				90	
	A216/B216 60#					100								65			50	
	A216/B216 60#						70								30		60	
	A217/B217 90#					150	150							130	75		90	
	A233 60#															60	35	62
	A234 90#								150	110						92	50	85
	A247 60#								150									57
	A247 60#									119							59	60
A248 80#								150							150		76	
A248 80#									150							93	82	
PTFE Diaphragm <sup>1</sup>	A203/B203 60#	70							55								55	
	A204/B204 90#	150							125								75	
	A206/B206 90#		150							150							90	
	A208/B208 60#		150	140						100	70						60	
	A208/B208 60#				100							35					70	
	A209/B209 90#			150	150						80	80					90	
	A216/B216 60#					125							70				50	
	A216/B216 60#						60								45		60	
	A217/B217 90#					150	150							125	70		90	
	A233 60#								50	30						20	15	62
	A234 90#								105	60						45	30	85
	A247 60#								133							68		61
	A247 60#									70								62
	A248 80#								150								114	82
A248 80#									150							70	90	

Fail Close Actuators - Air-To-Open, Spring-To-Close (Reverse Acting)																		
	Actuator and Spring Package	Maximum Line Pressure (bar)															Air pressure required to open for full stroke at 0 bar line pressure	
		Valve Size																
		100 % ΔP							0% ΔP									
	BT <sup>2</sup>	DN15	DN20	DN25	DN40	DN50	DN80	DN100	BT <sup>2</sup>	DN15	DN20	DN25	DN40	DN50	DN80	DN100		
Elastomer Diaphragm	A203/B203 60#	10,34							10,34								3,79	
	A204/B204 90#	10,34							10,34								5,17	
	A205/B205 60#		7,58							6,21							3,45	
	A206/B206 90#		10,34							10,34							6,21	
	A208/B208 60#			6,89							4,14						3,10	
	A208/B208 60#				4,83							2,75					4,14	
	A209/B209 90#			10,34	10,34						8,27	5,86					6,21	
	A216/B216 60#					6,89								4,48			3,45	
	A216/B216 60#						4,83								2,07		4,14	
	A217/B217 90#					10,34	10,34							8,96	5,17		6,21	
	A233 60#							6,55	4,83							4,14	2,41	4,28
	A234 90#							10,34	7,59							6,34	3,45	5,86
	A247 60#							10,34								6,34		3,93
	A247 60#								8,20								4,07	4,14
A248 80#							10,34								10,34		5,24	
A248 80#								10,34								6,41	5,65	
PTFE Diaphragm <sup>1</sup>	A203/B203 60#	4,83							3,79								3,79	
	A204/B204 90#	10,34							8,62								5,17	
	A206/B206 90#		10,34							10,34							6,21	
	A208/B208 60#		10,34	9,65						6,89	4,83						4,14	
	A208/B208 60#				6,89							2,41					4,83	
	A209/B209 90#			10,34	10,34						5,52	5,52					6,21	
	A216/B216 60#					8,62								4,83			3,45	
	A216/B216 60#						4,14								3,10		4,14	
	A217/B217 90#					10,34	10,34							8,82	4,83		6,21	
	A233 60#							3,45	2,07							1,38	1,03	4,28
	A234 90#							7,24	4,14							3,10	2,07	5,86
	A247 60#							9,17	4,83							4,69		4,21
	A247 60#																2,83	4,27
	A248 80#							10,34								7,86		5,65
A248 80#								10,34								4,83	6,21	

<sup>1</sup> The exposure of the diaphragm to steam may increase the air requirements to close by as much as 30%.

<sup>2</sup> Bio-Tek includes size 0.25" (DN8), 0.375" (DN10), and 0.5" (DN15).

Note: Values are also valid for the Advantage 2.0

# Advantage<sup>®</sup> 2.1, Series 33, Series 47 Actuator Sizing - Fail Open

P

Fail Open Actuators - Air-To-Close, Spring-To-Open (Direct Acting)																					
		Air Pressure Required to Close (psig)																			
Size	Bio-Tek <sup>2</sup>	0.5"		0.75"		1"		1.5"		2"		3"		4"		3"		4"			
Actuator	A103/B103	A105/B105		A108/B108		A108/B108		A116/B116		A116/B116		A133		A133		A147		A147			
Line	% ΔP																				
Pressure	100	0	100	0	100	0	100	0	100	0	100	0	100	0	100	0	100	0	100	0	
Elastomer Diaphragm	20	38	40	38	45	38	55	49	50	36	40	40	45	44	46	48	55	32	37	30	40
	40	40	42	40	50	42	60	52	61	38	44	45	50	50	58	55	69	41	44	36	47
	60	42	44	44	55	46	65	57	71	42	48	50	60	55	66	64	85	42	49	42	56
	80	46	48	48	60	50	70	61	80	44	52	56	70	61	76	72	90	44	56	48	66
	100	48	52	50	65	52	75	67	90	48	56	60	75	66	90	80	-	52	65	53	79
	125	52	56	54	70	60	85	73	-	50	60	64	80	78	-	90	-	63	73	59	90
	150	56	60	58	75	68	-	81	-	52	65	68	-	81	-	-	-	71	83	65	-
PTFE Diaphragm <sup>1</sup>	20	42	50	46	66	55	55	50	55	45	52	48	50	64	60	78	80	36	53	46	48
	40	44	52	50	68	58	60	55	60	50	56	50	60	68	78	84	90	44	60	52	66
	60	48	56	52	72	60	65	60	65	55	60	56	70	74	88	90	-	51	75	56	74
	80	52	60	56	76	65	70	65	70	60	64	64	80	78	-	-	-	55	85	62	81
	100	54	65	60	82	68	75	70	80	64	68	70	90	84	-	-	-	57	-	70	90
	125	58	70	64	86	74	80	75	-	68	72	76	-	90	-	-	-	59	-	79	-
	150	62	75	68	-	80	85	80	-	72	76	82	-	-	-	-	-	63	-	83	-

Fail Open Actuators - Air-To-Close, Spring-To-Open (Direct Acting)																					
		Air Pressure Required to Close (bar)																			
Size	Bio-Tek <sup>2</sup>	DN15		DN20		DN25		DN40		DN50		DN80		DN100		DN80		DN100			
Actuator	A103/B103	A105/B105		A108/B108		A108/B108		A116/B116		A116/B116		A133		A133		A147		A147			
Line	% ΔP																				
Pressure	100	0	100	0	100	0	100	0	100	0	100	0	100	0	100	0	100	0	100	0	
Elastomer Diaphragm	1,38	2,62	2,76	2,62	3,10	2,62	3,79	3,31	3,44	2,48	2,76	2,76	3,10	3,03	3,17	3,31	3,79	2,21	2,55	2,07	2,76
	2,76	2,76	2,90	2,21	3,45	2,70	4,14	3,58	4,20	2,62	3,03	3,10	3,45	3,45	4,00	3,79	4,76	2,83	3,03	2,48	3,24
	4,14	2,90	3,03	3,03	3,79	3,17	4,48	3,93	4,90	2,90	3,31	3,45	4,14	3,79	4,55	4,41	5,86	2,90	3,38	2,90	3,86
	5,52	3,17	3,31	3,31	4,14	3,45	4,83	4,20	5,57	3,03	3,56	3,86	4,83	4,21	5,24	4,97	6,21	3,03	3,86	3,31	4,55
	6,89	3,31	3,59	3,45	4,48	3,59	5,17	4,62	6,21	3,31	3,86	4,14	5,17	4,55	6,21	5,52	-	3,59	4,48	3,65	5,45
	8,62	3,59	3,86	3,72	4,83	4,14	5,86	5,03	-	3,45	4,13	4,41	5,52	5,38	-	6,21	-	4,34	5,03	4,07	6,21
	10,34	3,86	4,14	4,00	5,17	4,70	-	5,59	-	3,59	4,48	4,69	-	5,59	-	-	-	4,90	5,72	4,48	-
PTFE Diaphragm <sup>1</sup>	1,38	2,90	3,45	3,17	4,55	3,79	3,79	3,45	3,79	3,10	3,59	3,31	3,45	4,41	4,14	5,38	5,52	2,48	3,65	3,17	3,31
	2,76	3,03	3,59	3,45	4,70	4,00	4,14	3,79	4,14	3,45	3,86	3,45	4,14	4,69	5,38	5,79	6,21	3,03	4,14	3,59	4,55
	4,14	3,31	3,86	3,59	4,97	4,14	4,48	4,14	4,48	3,79	4,14	3,86	4,83	5,10	6,07	6,21	-	3,52	5,17	3,86	5,10
	5,52	3,59	4,14	3,86	5,24	4,48	4,83	4,48	4,83	4,14	4,41	4,41	5,52	5,38	-	-	-	3,79	5,86	4,27	5,58
	6,89	3,72	4,48	4,14	5,65	4,69	5,17	4,83	5,52	4,41	4,69	4,83	6,21	5,79	-	-	-	3,93	-	4,83	6,21
	8,62	4,00	4,83	4,41	5,93	5,10	5,52	5,17	-	4,69	4,97	5,24	-	6,21	-	-	-	4,07	-	5,45	-
	10,34	4,27	5,17	4,70	-	5,52	5,86	5,52	-	4,96	5,24	5,65	-	-	-	-	-	4,34	-	5,72	-

<sup>1</sup> The exposure of the diaphragm to steam may increase the air requirements to close by as much as 30%.

<sup>2</sup> Bio-Tek includes size 0.25" (DN8), 0.375" (DN10), and 0.5" (DN15).

Note: Values are also valid for the Advantage 2.0

# Advantage<sup>®</sup> 2.1, Series 33, Series 47 Actuator Sizing - Double Acting

P

Double Acting Actuators - Air-To-Close, Air-To-Open																					
Size		Air Pressure Required to Close (psig)																			
Bio-Tek <sup>2</sup>		0.5"		0.75"		1"		1.5"		2"		3"		4"		3"		4"			
Actuator	A303/B303	A305/B305		A308/B308		A308/B308		A316/B316		A316/B316		A333		A333		A347		A347			
Line	% ΔP																				
Pressure	100	0	100	0	100	0	100	0	100	0	100	0	100	0	100	0	100	0	100	0	
Elastomer Diaphragm	20	22	26	24	30	18	25	31	32	16	20	22	40	18	24	16	25	11	14	9	25
	40	24	28	26	35	20	30	34	43	20	25	26	45	26	29	24	38	17	21	15	30
	60	26	30	28	40	24	35	39	53	24	30	30	50	32	38	30	55	22	28	22	46
	80	28	32	32	45	26	40	44	62	28	35	35	55	38	48	38	68	23	35	27	60
	100	30	34	34	50	30	50	50	72	32	40	40	60	42	58	48	84	26	43	32	68
	125	32	38	38	55	34	55	55	89	36	45	45	70	52	68	58	-	34	53	40	76
PTFE Diaphragm <sup>1</sup>	20	34	36	34	36	28	30	25	35	25	34	35	40	38	38	42	44	19	33	31	37
	40	36	40	36	40	34	35	35	40	30	38	40	50	41	49	50	60	21	40	35	53
	60	40	44	40	46	38	40	45	50	35	42	50	60	47	58	56	74	29	46	44	59
	80	42	46	42	50	40	45	50	55	40	46	55	70	53	67	65	90	32	51	49	65
	100	44	52	44	54	42	50	55	60	45	50	60	80	58	78	73	-	35	58	54	77
	125	46	56	46	58	44	55	60	70	50	55	64	90	64	90	82	-	42	68	62	-
150	48	62	48	62	46	60	65	80	55	62	68	-	69	-	90	-	45	78	68	-	

Double Acting Actuators - Air-To-Close, Air-To-Open																					
Size		Air Pressure Required to Close (bar)																			
Bio-Tek <sup>2</sup>		DN15		DN20		DN25		DN40		DN50		DN80		DN100		DN80		DN100			
Actuator	A303/B303	A305/B305		A308/B308		A308/B308		A316/B316		A316/B316		A333		A333		A347		A147			
Line	% ΔP																				
Pressure	100	0	100	0	100	0	100	0	100	0	100	0	100	0	100	0	100	0	100	0	
Elastomer Diaphragm	1,38	1,51	1,79	1,65	2,07	1,24	1,72	2,14	2,21	1,10	1,38	1,52	2,76	1,24	1,66	1,10	1,72	0,76	0,79	0,62	1,72
	2,76	1,65	1,93	1,79	2,41	1,38	2,07	2,34	2,97	1,38	1,72	1,79	3,10	1,79	2,00	1,66	2,62	1,17	1,45	1,03	2,07
	4,14	1,79	2,07	1,93	2,75	1,65	2,41	2,69	3,66	1,65	2,07	2,07	3,45	2,21	2,62	2,07	3,79	1,52	1,93	1,52	3,17
	5,52	1,93	2,21	2,21	3,10	1,79	2,76	3,03	4,27	1,93	2,41	2,41	3,79	2,62	3,31	2,62	4,69	1,59	2,41	1,86	4,14
	6,89	2,07	2,34	2,34	3,45	2,07	3,45	3,45	4,96	2,21	2,76	2,76	4,14	2,90	4,00	3,31	5,79	1,79	2,96	2,21	4,69
	8,62	2,21	2,62	2,62	3,79	2,34	3,79	3,79	6,14	2,48	3,10	3,10	4,83	3,59	4,69	4,00	-	2,34	3,65	2,76	5,24
PTFE Diaphragm <sup>1</sup>	10,34	2,34	3,03	2,90	4,14	2,62	4,14	4,34	-	2,76	3,45	3,45	5,52	3,93	5,52	4,69	-	2,55	4,21	3,38	6,07
	1,38	2,34	2,48	2,34	2,48	1,93	2,07	1,72	2,41	1,72	2,34	2,41	2,76	2,62	2,62	2,90	3,03	1,31	2,28	2,14	2,55
	2,76	2,45	2,76	2,76	2,48	2,34	2,41	2,41	2,76	2,07	2,62	2,76	3,45	2,83	3,38	3,45	4,14	1,45	2,76	2,41	3,66
	4,14	2,76	3,03	2,76	3,17	2,62	2,76	3,10	3,45	2,41	2,90	3,45	4,14	3,24	4,00	3,86	5,10	2,00	3,17	3,03	4,07
	5,52	2,90	3,17	2,90	3,45	2,76	3,10	3,45	3,79	2,76	3,17	3,79	4,83	3,66	4,62	4,48	6,21	2,21	3,52	3,38	4,48
	6,89	3,03	3,57	3,03	3,72	2,90	3,45	3,79	4,14	3,10	3,45	4,14	5,52	4,00	5,38	5,03	-	2,41	4,00	3,72	5,31
8,62	3,17	3,86	3,17	4,00	3,03	3,79	4,14	4,83	3,45	3,79	4,41	6,21	4,41	6,21	5,66	-	2,90	4,69	4,28	-	
10,34	3,31	4,27	3,31	4,28	3,17	4,14	4,48	5,52	3,79	4,28	4,69	-	4,76	-	6,21	-	3,10	5,38	4,69	-	

<sup>1</sup> The exposure of the diaphragm to steam may increase the air requirements to close by as much as 30%.

<sup>2</sup> Bio-Tek includes size 0.25" (DN8), 0.375" (DN10), and 0.5" (DN15).

Note: Values are also valid for the Advantage 2.0

# ACS Actuator Sizing - Fail Close

P

Fail Close Actuators - Air-To-Open, Spring-To-Close (Reverse Acting)														
	Actuator and Spring Package	Maximum Line Pressure (psig)												Air pressure required to open for full stroke at 0 psi line pressure
		Valve Size												
		100% Δ P						0% Δ P						
		BP	.5"	.75"	1"	1.5"	2"	BP	.5"	.75"	1"	1.5"	2"	
Elastomer Diaphragm	ACS26 (60#)	150	120	100	80	100	70	125	50	60	45	65	30	58
	ACS2 (90#)	150						150						84
	ACS2 (90#)		150	150	150	150	150		150	120	130	130	75	90
PTFE Diaphragm	ACS26 (60#)	150	60	50	60	60	40	100	30	40	50	30	30	58
	ACS2 (90#)	150						150						84
	ACS2 (90#)		150	150	150	150	150		150	80	80	90	70	90

Fail Close Actuators - Air-To-Open, Spring-To-Close (Reverse Acting)														
	Actuator and Spring Package	Maximum Line Pressure (bar)												Air pressure required to open for full stroke at 0 psi line pressure
		Valve Size												
		100% Δ P						0% Δ P						
		BP	DN15	DN20	DN25	DN40	DN50	BP	DN15	DN20	DN25	DN40	DN50	
Elastomer Diaphragm	ACS26 (60#)	10,34	8,27	6,89	5,52	6,89	4,82	8,62	3,45	4,14	3,1	4,48	2,06	4,00
	ACS2 (90#)	10,34						10,34						5,79
	ACS2 (90#)		10,34	10,34	10,34	10,34	10,34		10,34	8,27	8,96	8,96	5,17	6,21
PTFE Diaphragm	ACS26 (60#)	10,34	4,14	3,45	4,14	4,14	2,75	10,34	2,07	2,75	3,45	2,06	2,06	4,14
	ACS2 (90#)	10,34						10,34						5,79
	ACS2 (90#)		10,34	10,34	10,34	10,34	10,34		10,34	5,52	5,52	6,21	4,83	6,21

# ACS Actuator Sizing - Fail Open

P

Air Pressure Required to Close (psig)													
	Size	BP		.5"		.75"		1"		1.5"		2"	
	Actuator	ACS1		ACS1		ACS1		ACS1		ACS1		ACS1	
Elastomer Diaphragm	Line Pressure	% ΔP											
		100	0	100	0	100	0	100	0	100	0	100	0
	20	46	43	38	45	38	55	28	40	36	40	40	45
	40	49	48	40	50	42	60	32	45	38	44	45	50
	60	52	52	44	55	46	65	36	55	42	48	50	60
	80	54	57	48	60	50	70	40	60	44	52	56	70
	100	57	61	50	65	52	75	45	70	48	56	60	75
	125	60	67	54	70	60	85	50	75	50	60	64	80
	150	63	72	58	75	68	-	55	85	52	65	68	-
PTFE Diaphragm	20	72	61	46	66	55	55	50	55	45	52	48	50
	40	75	66	50	68	58	60	55	60	50	56	50	60
	60	77	70	52	72	60	65	60	65	55	60	56	70
	80	79	74	56	76	65	70	65	70	60	64	64	80
	100	81	78	60	82	68	75	70	80	64	68	70	90
	125	84	83	64	86	74	80	75	-	68	72	76	-
150	86	88	68	-	80	85	80	-	72	76	82	-	

Air Pressure Required to Close (bar)													
	Size	BP		DN15		DN20		DN25		DN40		DN50	
	Actuator	ACS1		ACS1		ACS1		ACS1		ACS1		ACS1	
Elastomer Diaphragm	Line Pressure	% ΔP											
		100	0	100	0	100	0	100	0	100	0	100	0
	1,38	3,17	2,96	2,62	3,10	2,62	3,79	1,93	2,76	2,48	2,76	2,76	3,10
	2,76	3,38	3,31	2,21	3,45	2,70	4,14	2,21	3,10	2,62	3,03	3,10	3,45
	4,14	3,59	3,59	3,03	3,79	3,17	4,48	2,48	3,79	2,90	3,31	3,45	4,14
	5,52	3,72	3,93	3,31	4,14	3,45	4,83	2,76	4,14	3,03	3,56	3,86	4,83
	6,89	3,93	4,21	3,45	4,48	3,59	5,17	3,10	4,83	3,31	3,86	4,14	5,17
	8,62	4,14	4,62	3,72	4,83	4,14	5,86	3,45	5,17	3,45	4,13	4,41	5,52
	10,34	4,34	4,96	4,00	5,17	4,70	-	3,79	5,86	3,59	4,48	4,69	-
PTFE Diaphragm	1,38	4,96	4,21	3,17	4,55	3,79	3,79	3,45	3,79	3,10	3,59	3,31	3,45
	2,76	5,17	4,55	3,45	4,70	4,00	4,14	3,79	4,14	3,45	3,86	3,45	4,14
	4,14	5,31	4,83	3,59	4,97	4,14	4,48	4,14	4,48	3,79	4,14	3,86	4,83
	5,52	5,45	5,10	3,86	5,24	4,48	4,83	4,48	4,83	4,14	4,41	4,41	5,52
	6,89	5,58	5,38	4,14	5,65	4,69	5,17	4,83	5,52	4,41	4,69	4,83	6,21
	8,62	5,79	5,72	4,41	5,93	5,10	5,52	5,17	-	4,69	4,97	5,24	-
	10,34	5,93	6,07	4,70	-	5,52	5,86	5,52	-	4,96	5,24	5,65	-

# ACS Actuator Sizing - Double Acting

P

Air Pressure Required to Close (psig)													
	Size	BP		.5"		.75"		1"		1.5"		2"	
	Actuator	ACS3		ACS3		ACS3		ACS3		ACS3		ACS3	
Elastomer Diaphragm	Line Pressure	% ΔP											
		100	0	100	0	100	0	100	0	100	0	100	0
	20	21	15	24	30	18	25	12	20	16	20	22	40
	40	24	20	26	35	20	30	16	25	20	25	26	45
	60	27	24	28	40	24	35	20	35	24	30	30	50
	80	29	29	32	45	26	40	24	40	28	35	35	55
	100	32	33	34	50	30	50	28	50	32	40	40	60
	125	35	39	38	55	34	55	36	55	36	45	45	70
PTFE Diaphragm	150	38	44	42	60	38	60	44	65	40	50	50	80
	20	47	36	34	36	28	30	25	35	25	34	35	40
	40	50	41	36	40	34	35	35	40	30	38	40	50
	60	52	45	40	46	38	40	45	50	35	42	50	60
	80	54	49	42	50	40	45	50	55	40	46	55	70
	100	56	53	44	54	42	50	55	60	45	50	60	80
	125	59	58	46	58	44	55	60	70	50	55	64	90
150	61	63	48	62	46	60	65	80	55	62	68	-	

Air Pressure Required to Close													
	Size	BP		DN15		DN20		DN25		DN40		DN50	
	Actuator	ACS3		ACS3		ACS3		ACS3		ACS3		ACS3	
Elastomer Diaphragm	Line Pressure	% ΔP											
		100	0	100	0	100	0	100	0	100	0	100	0
	1,38	1,45	1,03	1,65	2,07	1,24	1,72	0,83	1,38	1,10	1,38	1,52	2,76
	2,76	1,65	1,38	1,79	2,41	1,38	2,07	1,10	1,72	1,38	1,72	1,79	3,10
	4,14	1,86	1,65	1,93	2,75	1,65	2,41	1,38	2,41	1,65	2,07	2,07	3,45
	5,52	2,00	2,00	2,21	3,10	1,79	2,76	1,65	2,76	1,93	2,41	2,41	3,79
	6,89	2,21	2,28	2,34	3,45	2,07	3,45	1,93	3,45	2,21	2,76	2,76	4,14
	8,62	2,41	2,69	2,62	3,79	2,34	3,79	2,48	3,79	2,48	3,10	3,10	4,83
PTFE Diaphragm	10,34	2,62	3,03	2,90	4,14	2,62	4,14	3,03	4,48	2,76	3,45	3,45	5,52
	1,38	3,24	2,48	2,34	2,48	1,93	2,07	1,72	2,41	1,72	2,34	2,41	2,76
	2,76	3,45	2,83	2,48	2,76	2,34	2,41	2,41	2,76	2,07	2,62	2,76	3,45
	4,14	3,59	3,10	2,76	3,17	2,62	2,76	3,10	3,45	2,41	2,90	3,45	4,14
	5,52	3,72	3,38	2,90	3,45	2,76	3,10	3,45	3,79	2,76	3,17	3,79	4,83
	6,89	3,86	3,65	3,03	3,72	2,90	3,45	3,79	4,14	3,10	3,45	4,14	5,52
	8,62	4,07	4,00	3,17	4,00	3,03	3,79	4,14	4,83	3,45	3,79	4,41	6,21
10,34	4,21	4,34	3,31	4,28	3,17	4,14	4,48	5,52	3,79	4,28	4,69	-	

# Pressure Drop Definition

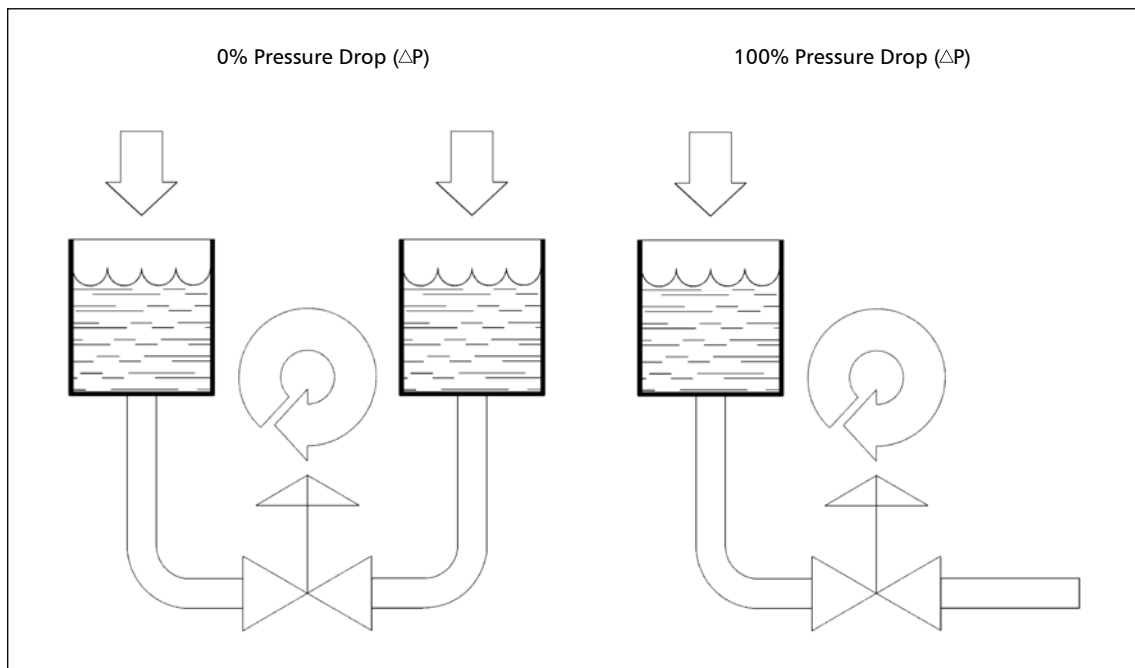

## Valve Stroke (approximate)

Valve Size		Pure-Flo Manual		EnviZion		ACS		Advantage 2.1		Advantage Series 33		Advantage Series 47	
Inch	DN	Inch	mm	Inch	mm	Inch	mm	Inch	mm	Inch	mm	Inch	mm
BP/BT/BV	6,10,15	0.16	4,1	0.16	4,1	0.16	4,1	0.16	4,0	NA	NA	NA	NA
0.5	15	0.25	6,3	0.25	6,3	0.25	6,4	0.25	6,4	NA	NA	NA	NA
0.75	20	0.38	9,6	0.45	11,4	0.38	9,7	0.30	7,6	NA	NA	NA	NA
0.75R	20	NA	NA	0.25	6,3	NA	NA	NA	NA	NA	NA	NA	NA
1	25	0.50	12,7	0.45	11,4	0.50	12,7	0.40	10,2	NA	NA	NA	NA
1.5	40	0.81	20,6	0.70	17,8	0.81	20,6	0.56	14,2	NA	NA	NA	NA
2	50	1.00	25,4	1.00	25,4	1.12	28,4	0.78	19,8	NA	NA	NA	NA
3	80	1.62	41,3	NA	NA	NA	NA	NA	NA	1.62	41,3	1.62	41,3
4	100	2.12	53,8	NA	NA	NA	NA	NA	NA	1.62	41,3	1.62	41,3

# Actuator Chamber Volume

## P Advantage 2.1, Series 33, Series 47 Actuators

Valve Size		Upper Chamber		Lower Chamber	
Inch	DN	in <sup>3</sup>	cm <sup>3</sup>	in <sup>3</sup>	cm <sup>3</sup>
0.25, 0.375, 0.5 <sup>1</sup>	6, 10, 15 <sup>1</sup>	2.62	43	2.26	37
0.5	15	5.49	90	4.27	70
0.75	20	12.51	205	7.63	125
1	25	12.08	198	9.15	150
1.5	40	71.00	1163	34.78	570
2	50	71.00	1163	38.75	635
3 (33)	80	160.35	2628	81.50	1336
4 (33)	100	160.35	2628	81.50	1336
3 (47)	80	463.80	7600	250.20	4100
4 (47)	100	463.80	7600	250.20	4100

<sup>1</sup> Bio-Tek sizes

## P Advantage Compact Stainless (ACS) Actuator

Valve Size		Fail Close		Fail Open		Double Acting		Double Acting	
		Lower Chamber		Upper Chamber		Lower Chamber		Upper Chamber	
Inch	DN	in <sup>3</sup>	cm <sup>3</sup>	in <sup>3</sup>	cm <sup>3</sup>	in <sup>3</sup>	cm <sup>3</sup>	in <sup>3</sup>	cm <sup>3</sup>
0.25, .31, 0.375, 0.5 <sup>1</sup>	6, 8, 10, 15 <sup>1</sup>	1.08	17,7	1.6	26,2	1.48	24,2	1.6	26,2
0.50	15	3.0	49,2	5.2	84,5	1.9	31,9	5.0	82,5
0.75	20	5.9	97,3	10.9	178,1	6.4	104,6	9.2	151,2
1.00	25	6.8	111,1	10.9	177,9	7.3	119,0	9.2	151,1
1.50	40	18.6	305,0	59.6	977,1	18.6	305,0	62.3	1020,9
2.00	50	22.0	361,3	59.6	977,1	23.4	384,3	62.1	1018,3

<sup>1</sup> Bio-Pure sizes

## E EnviZion Stainless Steel Actuator

Valve Size		Fail Close		Fail Open		Double Acting		Double Acting	
		Lower Chamber		Upper Chamber		Lower Chamber		Upper Chamber	
Inch	DN	in <sup>3</sup>	cm <sup>3</sup>	in <sup>3</sup>	cm <sup>3</sup>	in <sup>3</sup>	cm <sup>3</sup>	in <sup>3</sup>	cm <sup>3</sup>
0.50	15	5.7	93,4	5.9	96,7	5.7	93,4	5.1	83,6
0.75	20	9.8	160,6	11.5	188,5	9.8	160,6	9.6	157,3
1.00	25	9.8	160,6	11.5	188,5	9.8	160,6	9.6	157,3
1.50	40	26.4	432,6	71.0	1163,5	26.4	432,6	62.1	1017,6
2.00	50	31.0	508,0	71.0	1163,5	31.0	508,0	62.1	1017,6

## E EnviZion Advantage Actuator

Valve Size		Upper Chamber		Lower Chamber	
Inch	DN	in <sup>3</sup>	cm <sup>3</sup>	in <sup>3</sup>	cm <sup>3</sup>
0.75 & 1	20 & 25	12.08	198	9.15	150
1.50	40	71.00	1163	34.78	570
2.00	50	71.00	1163	38.75	635

# Flow Coefficients

## P $C_v$ Ratings for Advantage, ACS, 903, 913, 963, and 970 Topworks

Size (in)	0.50	0.75	1.00	1.50	2.00	2.50	3.00	4.00 <sup>1</sup>
10% Open	0.19	1.2	2.0	6.0	6	16.0	24	25.6
20% Open	0.38	2.4	3.8	11.5	11	29.6	44	56
30% Open	0.67	3.3	5.8	17.5	16	41.6	68	104
40% Open	1.14	4.1	7.6	22.5	21	52.0	92	160
50% Open	1.43	4.7	9.2	27.5	25	60.0	108	212
60% Open	1.90	5.2	10.9	31.5	31	66.4	124	232
70% Open	2.28	5.7	12.2	35.0	35	71.2	132	256
80% Open	2.66	6.0	13.3	35.0	41	75.2	136	288
90% Open	2.85	6.2	13.6	33.5	45	76.0	140	308
100% Open	3.33	6.2	13.6	28.0	51	76.0	144	320

<sup>1</sup>  $C_v$  for 4" valve full open with Advantage Actuator is 272.

## P $C_v$ Ratings for Advantage 2.1

Size (in)	0.50	0.75	1.00	1.50	2.00
10% Open	0.19	1.0	1.6	4.0	5
20% Open	0.38	1.9	3.2	9.0	10
30% Open	0.67	2.8	4.8	12.5	15
40% Open	1.14	3.5	6.2	16.5	19
50% Open	1.43	4.1	7.6	20.0	23
60% Open	1.90	4.6	8.9	23.5	28
70% Open	2.28	5.0	10.2	27.0	33
80% Open	2.66	5.5	11.3	30.5	38
90% Open	2.85	5.8	12.5	33.5	42
100% Open	3.33	6.0	13.3	35.5	46

## P $C_v$ Ratings for Bio-Tek

Size (in)	0.25	0.375	0.50
100% Open	0.89	1.92	2.1

## P $C_v$ Ratings for Bio-Pure

Size (in)	0.25	0.375	0.50
100% Open	0.47	1.10	1.60

## E $C_v$ Ratings for EnviZion Manual and Actuated (SS) Valves

Size (in)	BV	0.5"	0.75"	0.75"R	1"	1.5"	2"
25% Open		1.4	3.9	1.4	4.4	6.3	9.1
50% Open		2.5	7.4	2.9	9.5	17.3	24.9
75% Open		2.9	9.6	3.8	12.4	29.4	42.7
100% Open	2.1	3	10	4.5	14	37.1	51.2

## E $C_v$ Ratings for EnviZion Advantage Actuator

Size (in)	0.75"	1"	1.5"	2"
25% Open	3.9	4.4	6.3	8
50% Open	7.4	9.5	17.3	20
75% Open	9.6	12.4	29.4	35
100% Open	10	14	37.1	46

$C_v$  units = GPM with 1 psi pressure drop across valve.

# Flow Coefficients

## P $K_v$ Ratings for Advantage, ACS, 903, 913, 963, and 970 Topworks

Size (DN)	15	20	25	40	50	65	80	100 <sup>1</sup>
10% Open	0,16	1,0	1,7	5,2	5,2	13,6	20,4	21,8
20% Open	0,33	2,1	3,3	9,9	9,5	25,2	37,4	47,7
30% Open	0,58	2,9	5,0	15,1	13,8	35,4	57,8	88,5
40% Open	0,99	3,5	6,6	19,5	18,2	44,2	78,3	136,2
50% Open	1,23	4,1	8,0	23,8	21,6	51,0	91,9	180,4
60% Open	1,65	4,5	9,4	27,2	26,8	56,5	105,5	197,4
70% Open	1,97	4,9	10,6	30,3	30,3	60,6	112,3	217,8
80% Open	2,30	5,2	11,5	30,3	35,5	64,6	115,8	245,1
90% Open	2,47	5,4	11,8	29,0	38,9	64,6	119,1	262,1
100% Open	2,88	5,4	11,8	24,2	44,1	64,6	122,6	272,3

<sup>1</sup>  $K_v$  for DN100 valve full open with Advantage Actuator is 232.

## P $K_v$ Ratings for Bio-Tek

Size (DN)	6	10	15
100% Open	0,76	1,63	2,58

## P $K_v$ Ratings for Bio-Pure

Size (DN)	6	10	15
100% Open	0,40	0,95	1,36

## E $K_v$ Ratings for EnviZion Manual and Actuated (SS) valves

Size (DN)	BV	15	20	20R	25	40	50
25% Open		1.21	3.37	1.22	3.81	5.45	7.88
50% Open		2.16	6.40	2.51	8.22	14.98	21.56
75% Open		2.51	8.30	3.29	10.73	25.45	36.97
100% Open	1.83	2.60	8.65	3.89	12.11	32.12	44.33

$K_v = m^3/hr$  with 1  $Kg/cm^2$  pressure drop across the valve

## P $K_v$ Ratings for Advantage 2.1

Size (DN)	15	20	25	40	50
10% Open	0,16	0,9	1,4	3,5	4,3
20% Open	0,33	1,6	2,8	7,8	8,7
30% Open	0,58	2,4	4,2	10,8	13,0
40% Open	0,99	3,0	5,4	14,3	16,4
50% Open	1,23	3,5	6,6	17,3	19,9
60% Open	1,65	4,0	7,7	20,3	24,2
70% Open	1,97	4,3	8,8	23,4	28,5
80% Open	2,30	4,8	9,8	26,4	32,9
90% Open	2,47	5,0	10,8	29,0	36,3
100% Open	2,88	5,2	11,5	30,7	39,8

Note:  $K_v$  values expressed in  $m^3/h$  per one bar pressure drop.

## E $K_v$ Ratings for EnviZion Advantage Actuator

Size (DN)	20	25	40	50
25% Open	3.37	3.81	5.45	7.15
50% Open	6.40	8.22	14.98	17.89
75% Open	8.30	10.73	25.45	31.31
100% Open	8.65	12.11	32.12	41.15

## P ZeroStatic Block Body T Flow Reduction (% Reduction) Estimate of Reduction of $C_v$ (Standard 2-Way Valve Baseline)

Valve Size Run Size	BT 0.5" (DN15)	0.5" (DN15)	0.75" (DN20)	1" (DN25)	1.5" (DN40)	2" (DN50)
0.5" (DN15)	15.2	18.0	NA	NA	NA	NA
0.75" (DN20)	14.5	17.2	16.2	NA	NA	NA
1" (DN25)	13.8	16.3	15.4	23.5	NA	NA
1.5" (DN40)	13.1	15.5	14.6	22.3	25.5	NA
2" (DN50)	12.4	14.6	13.8	21.0	24.1	19.0
2.5" (DN65)	12.0	14.1	13.4	20.3	23.3	18.4
3" (DN80)	12.0	14.1	13.4	20.3	23.3	18.4
4" (DN100)	11.6	13.7	12.9	19.7	22.6	17.8

Notes: Consider entrance loss (at valve inlet) is similar to flow through branch of standard tee.

Reduced Flow vs.  
Standard 2 Way Valve

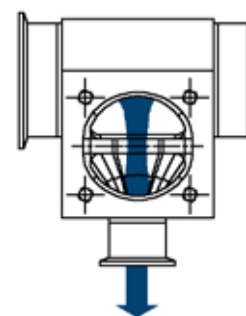

Example: 1.5" (DN40) Zero Static Tee with 3" (DN80) Run

$$\begin{aligned} \text{Approximate 100\% open } C_v &= \\ 28 - (23.3\%) (28) &= 21.5 C_v \\ &= 18,3 K_v \end{aligned}$$

# Validation & Qualification Documentation

Pure-Flo can provide the following documentation to aid the validation and qualification process upon request.

## Process Validation Documentation

- Certified Mill Test Reports
- Interior Surface Characterization
- Certification of compliance to specifications
- Certification of compliance to CFR Title #21 section 177
- USP Class VI compliance
- Quality assurance manual
- ISO 9001 certification
- Certification of testing to MSS SP-88

## Qualification Assistance

To assist you in compliance to IQs, OQs and PQs, a preventative maintenance program can be established for the changeout of diaphragms based on your passivation, cleaning, sterilization and process protocols.



Test Certificate		2005/3004047											
Date		30/06/2005											
Page		1											
INDUSTRIAL INC.		ITT ENGINEERED VALVES											
550 TEST RD.		33 CENTERVILLE ROAD											
17603 LANCASTER, PA		17603 LANCASTER, PA											
Customer Order	Delivery Note	Invoice	Delivered Qty										
869-STOCK	2005/003/0031635	IO 0031689	2.500,00										
Code Article	Place Description												
815002163106	BODY BIG TEK 113208 P/N 42409												
Material	Typ. Specification												
F316L89/1.4435	ASTM A182+DIN 17440-A ND BASEL STD EN2												
Heat Number	Steel Mill	Trade Mark	Forgin Code										
236913	TEST INDUSTRIAL		PM										
CHEMICAL ANALYSIS													
Item	Al	C	Cr	Cu	Ni	Mo	N	Mn	P	S	Si	Ti	
Min			17,000		2,500		12,500		0,0070		1,000	0,0050	
Max	0,010	0,030	18,000	0,500	2,000	0,0050	0,100	14,000	0,040	0,0070	1,000	0,0050	
Heat	0,0070	0,021	17,880	0,480	1,800	0,0050	0,090	13,760	0,038	0,041	0,420	0,0020	
IC.A.													
MECHANICAL PROPERTIES													
Laboratory Order	IP Description	UNC	Min	Max	Value	UNC	Value						
8045/PM/05	(01)TP Rp1.5 Abt 7	10/Awt	225,000		347,000	10/E1	50821,000						
8045/PM/05	(01)Rad 2k of Test Abt 7	10/Awt	180,000		274,000	10/E2	39730,000						
8045/PM/05	(01)Tens. Str. 30k Abt 7	10/Awt	490,000	690,000	920,000	10/E3	79395,000						
8045/PM/05	(01)5mm4x4 AA T Abt 1X	1X	30,000		45,700								
8045/PM/05	(01)10mm 30k AA T Abt 1X	1X	30,000		45,700								
8045/PM/05	(01)10mm Area Abt 7 2k 1X	1X	50,000		75,000								
8045/PM/05	(01)Impact 250 V Abt 7	1X	55,000		292,000								
8045/PM/05	(02)	1X	85,000		278,000								
8045/PM/05	(03)	1X	85,000		282,000								
Heat Treatment													
SOLUTION ANNEALED:													
ALL PIECES WERE HEATED TO 1940 F.													
HELD AT THIS TEMPERATURE FOR 1 HOUR FOR													
REACH 1" OF THICKNESS AND QUENCHED IN WATER.													
APPROVED													
BY													
NOV 3 0 2005													
3.1B CERTIFICATE ACCORDING TO EN 10204													
O. A. DEPARTMENT													
Signature: [Signature]													
Name: [Name]													
Title: [Title]													
1. The results of chemical analysis is a true and correct copy of the mill certificate issued by the manufacturer of the steel employed													
2. The material or components shipped under the above order number did not come in direct contact with mercury or any of its compounds, or with any mercury containing device employing a single boundary containment, during the manufacturing process, inspection or storage.													

ITT Engineered Valves, LLC		33 Centerville Road		Lancaster, PA 17603-0964		
Phone: (803) 865-1111		Fax: (717) 909-0398				
<b>ITT</b>						
<b>CERTIFICATE OF COMPLIANCE/ CONFORMANCE</b>						
Date Issued: August 10, 2023						
Customer:	Sample Cert	Quantity:	100			
Customer Order Number:	XXXXXX					
ITT Order Number:	Sample E1 Diaphragm					
ITT Line Number:	460					
ITT Part Number:	46607					
<b>Figure Number (Description)</b>						
46607 - DIAPHRAGM WR 02.00 MC EPDM E1						
<b>Additional Information</b>						
Part No	Description	Qty	Date Code	Cure Date	Lot No	Exp. Date
46607	DIAPHRAGM WR 02.00 MC EPDM E1	100	N/A	02/2023	9156688	02/2029
Extra Description: Grade E1 (EPDM) diaphragms have a LIMITED SHELF LIFE of 6 years.						
Grade E1 (EPDM) diaphragms comply with the FDA Code of Federal Regulations Title 21 Section 177.2600 with the exception of paragraph (f) "Rubber articles intended for repeated use in contact with baby food".						
Grade E1 (EPDM) diaphragms met USP <87> Elution Test (MEM) for Cytotoxicity and USP <88> tests for Class VI degradation.						
The maximum temperature rating for Grade E1 (EPDM) diaphragms is:						
184° F (80°C) for liquid applications,						
288° F (142°C) for continuous steam,						
302° F (150°C) for intermittent steam.						
Grade E1 (EPDM) Conforms to ASME BPE SD-2.6 Animal-Derived Ingredients.						
Grade E1 (EPDM) complies with EMEA/1001 Rev. 3 July 2011.						
Grade E1 (EPDM) meets ASME BPE Part 5.6, Section 5.3 & 5.4.						
Grade E1 (EPDM) is peroxide cured.						
Grade E1 (EPDM) is not made with natural rubber latex.						
Storage: Until the elastomer parts are installed, they should be kept in a covered, adequately ventilated, and dry location in their original containers. Storage temperature should not cycle rapidly, should be maintained between 40 and 120 degrees F.						
We certify that the components on the above referenced purchase order meet the requirements of the purchase order, applicable drawing(s), and our ISO 9001:2015 manufacturing, testing, and inspection processes to assure an acceptable quality level applicable to the product. These items are supplied in accordance with QMS Manual Rev 32 dated April 22, 2023.						
[Signature]						
Craig Stitzel						
Manager, Quality Assurance (or representative)						
(This Certificate was created electronically and is valid without signature)						

# Compliance

## 100% Interior Surface Finish Inspection:

- 100% visual inspection
- Statistical profilometer checks

## 100% Visual Weld Inspection:

- 100% visual inspection of fabrication welds
- Welds by ASME Section IX certified welders.
- 100% pressure test of fabricated welds

## Seat and Shell Test:

- Valves are seat and shell tested per MSS SP-88
- 100% inspection is available upon request

## 100% Final Assembly Inspection:

- All valve assemblies are 100% visually inspected prior to shipment

## Certified Mill Tests Reports:

- All valve bodies contain a heat number traceable to a Certified Mill Test Report (CMTR)
- CMTRs for weld wire, tubing, and fittings used in valve fabrications.

## Non-Destructive Testing:

(available upon request)

- Alloy Identity Testing identifies the chemical composition of material
- Liquid Penetration Inspection surface inspection capable of identifying subsurface porosity and weld defects
- Radiographic Inspection volumetric test capable of locating voids or inclusions within material

Leak and Shell Test



Alloy Identity Testing



# Approvals

## USDA Accepted

The Pure-Flo diaphragm valve is accepted by the USDA for use in federally inspected meat and poultry plants.

Selection from the following configurations is necessary to assure USDA acceptance.

### Body:

- 316L casting
- 316L forging
- Sizes: 0.5–4" (DN15–100)

### Interior Polishes:

- 35  $\mu\text{in}$  (0,89  $\mu\text{m}$ ) - 11  $\mu\text{in}$  (0,28  $\mu\text{m}$ ), see page B-7 for Surface Finish chart.
- Electropolish exterior (optional)

### End Connections:

- Hygienic Tri-Clamp
- Other options available upon request

### Diaphragms:

- Black Butyl
- Buna N
- EPDM
- PTFE

### Bonnets:

- White epoxy
- PVDF coatings
- Stainless steel

Stainless Steel Valve Bodies



Grade TME PTFE and Grade E1 EPDM Diaphragms



# ASME Bioprocessing Equipment Standard (ASME BPE)

## Scope:

The BPE standard was created to develop requirements for the design, materials, construction, inspection, and testing of vessels, piping, and related accessories such as pumps, valves, and fittings for use in the biopharmaceutical industry.

Pure-Flo valves are manufactured in accordance with applicable portions of the ASME BPE.

The BPE standard applies to all parts of equipment and piping that contact:

- Finished product
- Raw materials
- Product intermediates

This includes systems such as:

- Water-for-injection (WFI)
- Clean steam
- Purified water
- Ultrafiltration
- Intermediate product storage

## The BPE is divided into sections or “Parts”

### Part SD - Design for Sterility & Cleanability

Outlines accepted practices for the fabrication of bioprocessing equipment that is both Cleanable and Sterilizable.

- Cleanability
- Sterility
- Dead Legs  $L/D = 2:1$  target
- Drainability
- Preferred, recommended, and not recommended designs

### Part DT - Dimensions and Tolerances

Establishes acceptable dimensions, tolerances, and markings. This section is not intended to cover valves.

### Part DT - V - Dimensions and Tolerances - Valves

Addresses valve related criteria including:

- Dimensions
- Tolerances
- Reduced sulfur content 316L specification
- Weld end tangent lengths
- Product marking information

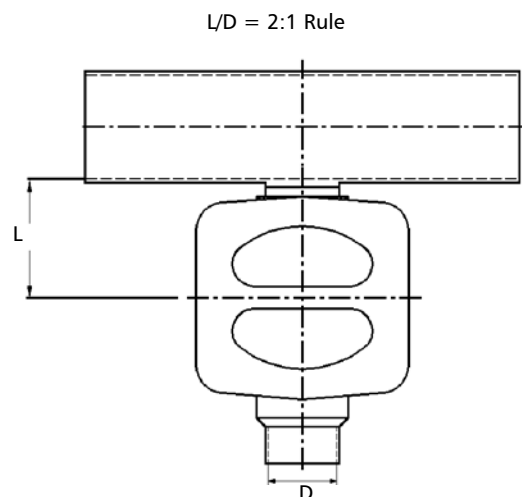

# ASME Bioprocessing Equipment Standard (ASME BPE)

## Part MJ - Materials Joining

Establishes requirements for the joining of bioprocessing equipment.

Weld beads acceptance criteria for:

- Misalignment
- OD / ID concavity
- Lack of penetration
- Convexity
- Width variation
- Meander

## Part SF - Process Contact Surface Finishes

Specification of interior surface finishes for vessels, distribution systems, and other components having product contact.

- Ra measurements (profilometer)
- Mechanical polish and electropolish requirements
- Visual acceptance criteria

## Part SG - Sealing Components

Establishes requirements for various mechanical seals and gaskets including valve diaphragms.

- Biocompatibility - compliance to USP Class VI
- Leakage rates
- Process compatibility

Chemical Compositions per ASME BPE MM 2.1-1 with controlled sulfur (.005-.017%)

### ASME Table SF-2.4-1 R<sub>a</sub> Readings for Valves

Mechanically Polished or any other finishing method that meets the R<sub>a</sub> Max

Code	R <sub>a</sub> MAX	
	μ-in.	μm
SF1	20	0.51
SF2	25	0.64
SF3	30	0.76

Mechanically Polished and Electropolished

Code	R <sub>a</sub> MAX	
	μ-in.	μm
SF4	15	0.38
SF5	20	0.51
SF6	25	0.64

General Notes:

1. All Ra readings are taken across the lay, wherever possible.
2. No single R<sub>a</sub> reading shall exceed the R<sub>a</sub> max. value in this table.
3. Other R<sub>a</sub> readings are available if agreed upon between owner/user and manufacturer, not to exceed values in this table.

# European Union Directives

European Union Directives apply to categories of equipment. CE Marking is applied to products where applicable.

## Relevant Directives for Valves

- Pressure Equipment Directive (PED) 2014/68/EU
- Electromagnetic Compatibility Directive (EMC) 2014/30/EU
- Low-Voltage Directive (LVD) 2014/35/EU
- Safety of Machinery Directive 2006/42/EC
- Equipment for Explosive Atmospheres (ATEX) 2014/34/EU

## PED - Pressure Equipment Directive 2014/68/EU

- The nominal size (DN)
- Maximum allowable pressure
- State of the intended fluid contents (gas or liquid)
- The classification of the intended fluid contents (Group 1 or 2 as defined in Council Directive Regulation (EC) No 1272/2008)
- Fluid categories (Liquid or Gas)

### Group 1

- Explosive
- Extremely flammable
- Highly flammable
- Flammable (where max allowable temp is above flashpoint)
- Very toxic
- Toxic
- Oxidizing

### Group 2

- All other fluids including steam

## PED Compliance Categories

- Sound Engineering Practice "SEP"
- Valves < 1" (DN25) by definition
- "CE" can not be marked
- Category I
- Valves > 1"(DN25) and < 6"(DN150)
- "CE" is marked



P	Valve Size		PN Rating Stainless Steel Bonnet	PN Rating PAS Bonnet	Suitable Fluid Categories			
	DN	Inch			Liquid Group 2	Liquid Group 1	Gas Group 2	Gas Group 1
	6 <sup>1</sup>	0.25 <sup>1</sup>	10.3	10.3	SEP	SEP	SEP	SEP
	10 <sup>1</sup>	0.375 <sup>1</sup>	10.3	10.3	SEP	SEP	SEP	SEP
	15 <sup>1</sup>	0.5 <sup>1</sup>	10.3	10.3	SEP	SEP	SEP	SEP
	15	0.5	13.8	10.3	SEP	SEP	SEP	SEP
	20	0.75	13.8	10.3	SEP	SEP	SEP	SEP
	25	1	13.8	10.3	SEP	SEP	SEP	SEP
	40	1.5	12.1	10.3	I	I	I	I
	50	2	12.1	10.3	I	I	I	I
	65	2.5	10 <sup>2</sup>	10 <sup>2</sup>	I	I	I	I
	80	3	10 <sup>2</sup>	10 <sup>2</sup>	I	I	I	I
	100	4	10 <sup>2</sup>	10 <sup>2</sup>	I	I	I	I

<sup>1</sup> Bio-Pure and Bio-Tek

<sup>2</sup> Derated to 145 psi / 10 bar from standard product

# European Union Directives

## EMC - Electromagnetic Compatibility Directive 2014/30/EU

The EMC Directive covers any apparatus liable to cause electromagnetic disturbance or can be affected by such disturbance.

Included Apparatus:

- Solenoid valves
- Proximity switches
- Electro Pnuematic positioners
- Electro Pnuematic transducers

Excluded Apparatus:

- Limit switches
- "CE" Marked

## LVD - Low Voltage Directive 2014/35/EU

- Electrical equipment rated between 50 - 1000 VAC, 75-1500 VDC
- EC Declaration of Conformity required
- "CE" marked

## Safety of Machinery Directive 2006/42/EC

- An assembly of linked parts or components, at least one of which that moves
- Manual valves are excluded from this directive

EG-Konformitätserklärung / EC-Declaration of Conformity

Hiermit erklären wir, / We herewith declare,

**ITT Bornemann GmbH**  
Postfach 11 62, 31676 Oberkirchen, Germany  
Fon +49 (0) 5724 390-0, Fax +49 (0) 5724 390-290.

dass die Ventile der Baureihen / that the valves of the series

**Pure-Flo, EnviZion, BioviZion, Dia-Flo**

Übereinstimmen mit folgenden EG-Richtlinien, sofern die in den technischen Unterlagen, insbesondere in der Betriebsanleitung, genannten Voraussetzungen für die Inbetriebnahme erfüllt sind:

are in conformity with the following EC-Directives, provided that the site conditions for the commissioning are met as specified in the engineering documents, in particular in the operation manual:

Maschinenrichtlinie (2006/42/EG) / Machinery - Directive (2006/42/EC)

Angewandte harmonisierte Normen / Harmonized standards used:

- EN 19
- EN 12516-3

Für die Zusammenstellung der technischen Unterlagen ist bevollmächtigt: /  
Person authorized to compile the technical file: Maik Spannuth - Quality Manager

Oberkirchen, Datum / date: 17.02.2021

  
**Dr. Arne Stuckenberg**  
Geschäftsführer  
Managing Director

  
**ppa. Gerhard Rohlfing**  
Technischer Leiter  
Technical Manager

02/2021, Rev. 00 [www.bornemann.com](http://www.bornemann.com) 

 **ITT** |   
Manufactured by 

**Declaration of Conformity**  
2014/30/EU (EMC)

Authorized Representative of Engineered Valves within the EU

**ITT Bornemann GmbH**  
Industriestrasse 2  
31683 Oberkirchen, Germany  
Tel.: +49 5724 390-0  
Fax: +49 5724 390-290

We hereby certify under our sole responsibility that the products listed below to which this declaration relates to, are in conformity with the essential requirements of the EU directive Electromagnetic Compatibility 2014/30/EU.

**Switch Package Models: VSPN, VSP+N, SP2X**

The switch-pack was independently assessed by third party for compliance with EMC 2014/30/EU. Certificate number: B3611TC2

The certificate was commissioned by Divisions of ITT Industries Ltd Axminster.

The following standard was applied with respect to the compliance with EMC 2014/30/EU:  
EN 61326-2-6:2013

Authorized Representative

  
**M. Riese**  
General Manager

Date: 19-10-2020

# ATEX Directive 2014/34/EU

- Institutes uniform controls on equipment intended for use in potentially explosive atmospheres (PEAs) within the EU and European Economic Area (EEA)
- Compliance mandatory on July 1, 2003 - All equipment intended for use in potentially explosive atmospheres, defined as machines, apparatus, fixed or mobile devices, control components and instrumentation which, separately or jointly, are capable of causing an explosion through their own potential sources of ignition.
- Facility owners must classify potentially explosive atmospheres into Zones
- Products must be classified into Equipment Groups and Categories
- Pure-Flo valves are Equipment Group II products
  - Zone 0 environments require Category 1 hardware
  - Zone 1 environments require Category 1 or 2 hardware
  - Zone 2 environments require Category 1, 2, or 3 hardware
  - A facility must specify whether the hazard present is due to gas or dust. The ATEX Directive treats these hazards differently and outlines different methods of protection
  - An equipment manufacturer must provide
    - ambient temperature range
    - maximum surface temperature
- All products must be assessed as a system. The compliance of individual components is not sufficient justification for deeming the assembly as ATEX approved.
- All ATEX approved products must bear a CE mark
- A Declaration of Conformity and Instructions for Safe Use are supplied as required
- Manufacturers and Users are responsible for compliance

**ITT** | **Engineered Valves**  
Manufactured by **Bormann**

**Declaration of Conformity**  
2014/34/EU (ATEX)

Authorized Representative of Engineered Valves within the EU

**ITT Bormann GmbH**  
Industriestraße 2  
31683 Oberkirchen, Germany  
Tel: +49 5724 390-0  
Fax: +49 5724 390-290

We hereby certify that the products listed below satisfy the requirements set forth in the Directive of the Committee for the Harmonization of Legal Regulations of Member States concerning *Equipment and Protective Systems Intended for use in Potentially Explosive Atmospheres* (ATEX 2014/34/EU).

**Assemblies of ITT valve with Advantage® Actuator Models:**  
A205/B205/A204/B204/A205/B206/A206/B206/A208/B208/A209/B209/A216/B216/A217/B217/A105/B105/A105/B105/A108/B108/A116/B116/A303/B303/A305/B305/A308/B308/A316/B316

The following standard was consulted with respect to the compliance with ATEX 2014/34/EU:  
EN60079-36:2016 Non-electrical equipment for potentially explosive atmospheres

ATEX Conformity Assessment Module A – Internal Production Control, Technical Files ref W902  
Signed with Notified Body

The marking of the equipment listed above includes the following:

**II 2 G Ex h IIB TX Gb**  
**II 2 D Ex h IIIC TX Db**

Consult the *Instructions for Safe Use* for further information on using this equipment in potentially explosive environments.

Authorized Representative:  
M. Bormann  
General Manager

Date: 19-10-2020

**ITT** | **Engineered Valves**  
Manufactured by **Bormann**

**Declaration of Incorporation**  
Machinery Directive 2006/42/EC

Authorized Representative of Engineered Valves within the EU

**ITT Bormann GmbH**  
Industriestraße 2  
31683 Oberkirchen, Germany  
Tel: +49 5724 390-0  
Fax: +49 5724 390-290

In accordance with The Machinery Directive 2006/42/EC, we hereby declare that for the partly completed machinery identified as 'ACTUATED DIAPHRAGM VALVES' (the EHSR's referred to in Annex I of the PED) have been complied with and a Technical File has been compiled in accordance with Annex VII (B) of The Machinery Directive.

Valve Type	Actuated Diaphragm valve
Body Models	Pure Flo and Invention (Flanged and Wrought)
Actuator Models	Advantage, Advantage 2D, Advantage 2 L, ACS, APA, ASS, Dia Flo, ZA
End connections	BW, Trilamp, Flanged and Screwed

The incomplete machinery (tube or valve assembly) to which this Declaration of Incorporation refers must not be put in service until the relevant machinery into which it is to be incorporated has been declared in conformity with the provisions of the Machinery Directive 2006/42/EC.

ITT Industrie untersteht in diesem, in response to a request by national authorities, relevant information on the partly completed machinery by the following method of transmission: Paper.

Authorized Representative:  
M. Bormann  
General Manager

Date: 19-10-2020

# Sample & Bleed Valves

## Section H

### Application

The Pure-Flo product line of Sample and Bleed Valves provides compact and economical means to extract process samples and bleed off excess condensate while maintaining product sterility.

### Benefits

Stagnant fluid inherent to the take-off leg of a conventional diaphragm or ball valve sample valve is eliminated in the Pure-Flo Sample Valve. By providing a stainless steel metal to metal shut off directly at the Tri-Clamp®, the typical take-off leg is eliminated.

Pure-Flo Sample and Bleed Valves are available in Sample, Zero Static Sample, and Bleed, and with a number of standard and optional features to best suit your system design.

Sample and Bleed Valves are manufactured from 316L stainless steel and utilize a thermoplastic handwheel so that they can withstand typical cleaning and sterilization protocols, including autoclaving.

The relatively simple design utilizing “off the shelf” o-ring seals allows for easy replacement of sealing components.

The Sample Valve handle and stem are designed to provide smooth operation and limited wear on the internal components.

The Zero Static Sample Valve can be installed directly in line and allows a sample to be taken or condensate to be drained without the typical hold up volume or contact surfaces inherent to branch valve assemblies.

The Bleed valve is a simple but effective design for providing a quick and easy way to asperate or drain a system. These are often used for filter housings, bubble traps, and small tanks. An optional weld end allows the bleed valve to become an integral part of any assembly.

All product contact materials are FDA compliant.



### Standard Features

- Body Material: 316L
- O-Ring/Seal Material: EPDM FDA compliant, USP Class VI
- Handwheel Material: Polyphenylsulfone
- Standard Interior Surface Finish: 11 $\mu$ in (0,3 $\mu$ m) Ra
- Electropolish: Interior and Exterior
- Inlet End Connection: Tri-Clamp®
- Outlet End Connection: Tri-Clamp®, Butt-weld, Hose Barb
- Maximum Temperature/Pressure: 135°C (275°F) 100 psi (7,0 bar)
- Autoclavable

### Available Options

- Body Material: 1.4435, AL6XN, C276, C22
- O-Ring Seal Material: Viton - FDA compliant, Viton - FDA compliant and USP Class VI
- End Connections: ISO/DIN
- Outlet Option: 2nd outlet, steaming port
- Operation: Toggle style handle available on sample valve and zero-static sample valve
- Other options available upon request

# Sample Valves

Sample Valve

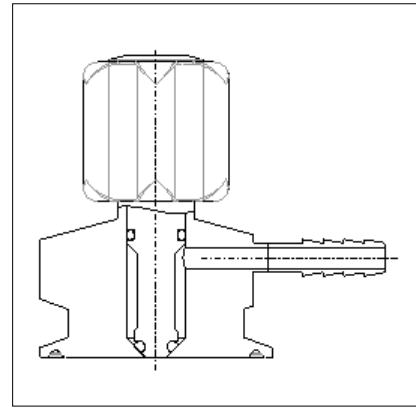

Zero Static Sample Valve

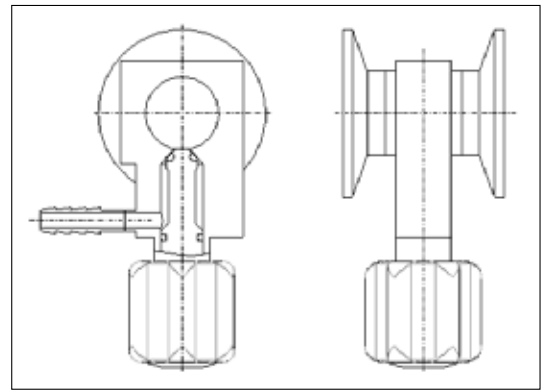

Toggle Style Operation

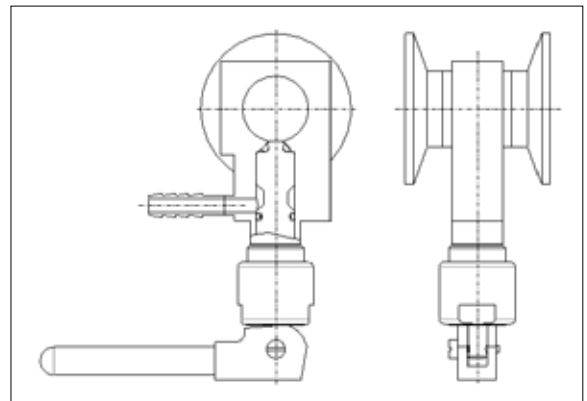

# Bleed Valve

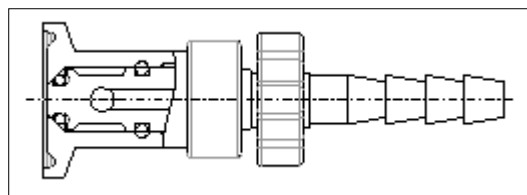

Drawing is an example of a customer specific sample valve drawing

## Sample valve configurations

### Standard configuration

SV – W – 1 – 419 - .38 – X41 – EPDM

Code	SV	W	1	419	.38	X41	EPDM
Description	Valve type	Material	Inlet size	Inlet end connection	Outlet size	Outlet end connection	O-ring type

### Special configuration

SV-WD-.5-419-34-.25-X19S1-34-VIT-SPEC:2nd Outlet 0.25"-PER DRAWING:K18000-MAX FERR:3%

Code	SV	WD	.5	419	34	.25	X19S1
Description	Valve type	Material	Inlet size	Inlet end connection	Special inlet Tri-clamp	Outlet size	Outlet end connection

34	VIT	SPEC: 2nd Outlet 0.25"	Per Drawing: K18000	MAX FERR:3%
Special outlet Tri-clamp	O-ring type	Special outlet configurations	Special	Controlled ferrite

## Options

### Valve Type (Block valve)

Code	Description	Inlet/run sizes	End Connections	Outlet sizes	End Connections
SV	Sample valve	¼ - 4.0"	TC / BW / SPEC	1/8 – 1/2	TC / BW / HB / SPEC
ZSS	Zerostatic sample valve	¼ - 4.0"	TC / BW / SPEC	1/8 – 1/2	TC / BW / HB / SPEC
BV	Bleed valve	¼ - 4.0"	TC / BW / SPEC	1/8 – 3/8	HB ONLY
SV-TSH	Toggle sample valve	¼ - 4.0"	TC / BW / SPEC	1/8 – 1/2	TC / BW / HB / SPEC
ZSS-TSH	Toggle zerostatic sample valve	¼ - 4.0"	TC / BW / SPEC	1/8 – 1/2	TC / BW / HB / SPEC
SPEC	Special sample valve	¼ - 4.0"	TC / BW / SPEC	1/8 – 1/2	TC / BW / HB / SPEC

# Model Codes

## Valve Type

Code	Description
SV	Sample valve
ZSS	Zerostatic sample valve
BV	Bleed valve
SPEC	Special

## Operation option

Code	Description
TSH	Toggle style handle

## Material

Code	Description
W	316L SS
WD	1.4435 SS
WA	AL-6XN
WC6	Hastelloy c-276
WC2	Hastelloy c-22
OTH	Other material

## Inlet/run size

Code	Description
0.25	¼" (DN06)
0.38	3/8" (DN10)
0.5	½" (DN15)
0.75	¾" (DN20)
1.0	1" (DN25)
1.5	1 ½" (DN40)
2.0	2" (DN50)
2.5	2 ½" (DN65)
3.0	3" (DN80)
4.0	4" (DN100)

## Inlet/run end connection

Code	Description
419S2	Tri-Clamp 14 Gauge
419	Tri-Clamp 16 Gauge
419S	Tri-Clamp 18 Gauge
419S1	Tri-Clamp 20 Gauge
429	Buttweld 14 Gauge
428	Buttweld 16 Gauge
423	Buttweld 18 Gauge
424	Buttweld 20 Gauge
SPEC	Special

## Outlet size

Code	Description
0.13	1/8" (DN04)
0.25	¼" (DN06)
0.38	3/8" (DN10)
0.5	½" (DN15)

## Outlet end connection

Code	Description
X19	Tri-Clamp 16 Gauge
X19S	Tri-Clamp 18 Gauge
X19S1	Tri-Clamp 20 Gauge
X28	Buttweld 16 Gauge
X23	Buttweld 18 Gauge
X24	Buttweld 20 Gauge
X40	Hosebarb 16 Gauge
X41	Hosebarb 18 Gauge
SPEC	Special

## O-ring type

Code	Description
EPDM	EPDM o-ring (FDA & USP CLASS VI)
VIT (Obsolete)	Viton o-ring (FDA)
VITUSP	Viton o-ring (FDA & USP CLASS VI)

## Special inlet tri-clamp diameter

Code	Description
25	25mm Tri-clamp
34	34mm Tri-clamp
50.5	50.5mm Tri-clamp

## Special outlet tri-clamp diameter

Code	Description
25	25mm Tri-clamp
34	34mm Tri-clamp
50.5	50.5mm Tri-clamp

## Special outlet configuration

Code	Description
Spec	Special (text box)

## Special tagging

Code	Description
RTAG	STN STL round tag
STAG	STN STL square tag
SPEC	Special tag
CHAIN	STN STL chain
TIE	Plastic tie wrap
WIRE	STN STL wire

# Figure Number Cross Reference

## Bleed Valve

PFCA Part Number	Old Figure Number	New Figure Number	Description
S100855	BV-BL-HB-BL-01	-	BLEED VLV ASSY, BL X .125, BL X HB, 11 PG A 316L/EPVIT
S101490	BV-NPT-HB-02-02	-	BLEED VLV ASSY, .250 X .250, MNPT X HB, 11 PG A 316L/EPVIT
S100856	BV-BL-HB-BL-02	-	BLEED VLV ASSY, BL X .250, BL X HB, 11 PG A 316L/EPVIT
S100824	BV-TC-HB-04-01	BV-W-.5-419-.13-X41-EPVIT	BLEED VLV ASSY, .500 X .125, TC X HB, 11 PG A 316L/EPVIT
S100825	BV-TC-HB-04-02	BV-W-.5-419-.25-X41-EPVIT	BLEED VLV ASSY, .500 X .250, TC X HB, 11 PG A 316L/EPVIT
S100826	BV-TC-HB-12-01	BV-W-1.5-419-.13-X41-EPVIT	BLEED VLV ASSY, 1.50 X .125, TC X HB, 11 PG A 316L/EPVIT
S100827	BV-TC-HB-12-02	BV-W-1.5-419-.25-X41-EPVIT	BLEED VLV ASSY, 1.50 X .250, TC X HB, 11 PG A 316L/EPVIT
S100828	BV-TC-HB-16-02	BV-W-2-419-.25-X41-EPVIT	BLEED VLV ASSY, 2.00 X .250, TC X HB, 11 PG A 316L/EPVIT

## Bleed Valve with Viton O-Rings

PFCA Part Number	Old Figure Number	New Figure Number	Description
S102585	-	BV-W-.5-419-.25-X41-VITUSP	BLEED VLV ASSY, .500 X .250, TC X HB, 11 PG A 316L/VITON

## Sample Valve

PFCA Part Number	Old Figure Number	New Figure Number	Description
S101848	SV-TC-HB-04-01	SV-W-.5-419-.13-X41-EPDM	SAMPLE VLV ASSY, .500 X .125, TC X HB, 11 PG A 316L/EPDM
S100829	SV-TC-HB-04-02	SV-W-.5-419-.25-X41-EPDM	SAMPLE VLV ASSY, .500 X .250, TC X HB, 11 PG A 316L/EPDM
S100831	SV-TC-HB-04-03	SV-W-.5-419-.38-X41-EPDM	SAMPLE VLV ASSY, .500 X .375, TC X HB, 11 PG A 316L/EPDM
S101612	SV-TC-HB-04-04	SV-W-.5-419-.5-X40-EPDM	SAMPLE VLV ASSY, .500 X .500, TC X HB, 11 PG A 316L/EPDM
S101849	SV-TC-HB-12-01	SV-W-1.5-419-.13-X41-EPDM	SAMPLE VLV ASSY, 1.50 X .125, TC X HB, 11 PG A 316L/EPDM
S100832	SV-TC-HB-12-02	SV-W-1.5-419-.25-X41-EPDM	SAMPLE VLV ASSY, 1.50 X .250, TC X HB, 11 PG A 316L/EPDM
S102228	-	-	SAMPLE VLV ASSY, 1.50 X .250, TC X 45HB, 15 PG A 316L/EPDM
S100833	SV-TC-HB-12-03	SV-W-1.5-419-.38-X41-EPDM	SAMPLE VLV ASSY, 1.50 X .375, TC X HB, 11 PG A 316L/EPDM
S100834	SV-TC-HB-12-04	SV-W-1.5-419-.5-X40-EPDM	SAMPLE VLV ASSY, 1.50 X .500, TC X HB, 11 PG A 316L/EPDM
S100835	SV-TC-HB-16-02	SV-W-2-419-.25-X41-EPDM	SAMPLE VLV ASSY, 2.00 X .250, TC X HB, 11 PG A 316L/EPDM
S100836	SV-TC-HB-32-02	SV-W-4-419S2-.25-X41-EPDM	SAMPLE VLV ASSY, 4.00 X .250, TC X HB, 11 PG A 316L/EPDM
S100837	SV-TC-TC-04-02	SV-W-.5-419-.25-X19S1-EPDM	SAMPLE VLV ASSY, .500 X .250, TC X TC, 11 PG A 316L/EPDM
S100838	SV-TC-TC-04-04	SV-W-.5-419-.5-X19-EPDM	SAMPLE VLV ASSY, .500 X .500, TC X TC, 11 PG A 316L/EPDM
S100839	SV-TC-TC-12-02	SV-W-1.5-419-.25-X19S1-EPDM	SAMPLE VLV ASSY, 1.50 X .250, TC X TC, 11 PG A 316L/EPDM
S100840	SV-TC-TC-12-04	SV-W-1.5-419-.5-X19-EPDM	SAMPLE VLV ASSY, 1.50 X .500, TC X TC, 11 PG A 316L/EPDM
S101487	SV-BL-HB-BL-02	-	SAMPLE VLV ASSY, BL X .250, BL X HB, 11 PG A 316L/EPDM
S102180	-	-	SAMPLE VLV ASSY, BL X .250, BL X WE, ACT, 11 A 316L/EPDM
S102181	-	-	SAMPLE VLV ASSY, .500 X .500, TC X TC, ACT, 11 A 316L/EPDM

# Figure Number Cross Reference

## Sample Valve with Viton O-Rings

PFCA Part Number	Old Figure Number	New Figure Number	Description
S102582	-	SV-W-.5-419-.25-X41-VITUSP	SAMPLE VLV ASSY, .500 X .250, TC X HB, 11 PG A 316L/VITON
S102583	-	SV-W-.5-419-.5-X19-VITUSP	SAMPLE VLV ASSY, .500 X .500, TC X TC, 11 PG A 316L/VITON
S102584	-	SV-W-1.5-419-.25-X41-VITUSP	SAMPLE VLV ASSY, 1.50 X .250, TC X HB, 11 PG A 316L/VITON
S102586	-	SV-W-.5-419-.25-X19S1-VITUSP	SAMPLE VLV ASSY, .500 X .250, TC X TC, 11 PG A 316L/VITON

## Zero Static Sample Valve

PFCA Part Number	Old Figure Number	New Figure Number	Description
S100842	ZSS-TC-HB-02-02	ZSS-W-.25-419S1-.25-X41-EPDM	SAMPLE VLV ZS ASSY, .250 X .250, TC X HB, 11 PG A 316L/EPDM
S100843	ZSS-TC-HB-04-02	ZSS-W-.5-419-.25-X41-EPDM	SAMPLE VLV ZS ASSY, .500 X .250, TC X HB, 11 PG A 316L/EPDM
S100844	ZSS-TC-HB-04-03	ZSS-W-.5-419-.38-X41-EPDM	SAMPLE VLV ZS ASSY, .500 X .375, TC X HB, 11 PG A 316L/EPDM
S100841	ZSS-TC-WE-06-02	ZSS-W-.75-419-.25-X24-EPDM	SAMPLE VLV ZS ASSY, .750 X .250, TC X WE, 11 PG A 316L/EPDM
S100845	ZSS-TC-HB-06-02	ZSS-W-.75-419-.25-X41-EPDM	SAMPLE VLV ZS ASSY, .750 X .250, TC X HB, 11 PG A 316L/EPDM
S100846	ZSS-TC-HB-06-04	ZSS-W-.75-419-.5-X40-EPDM	SAMPLE VLV ZS ASSY, .750 X .500, TC X HB, 11 PG A 316L/EPDM
S100847	ZSS-TC-HB-08-02	ZSS-W-1-419-.25-X41-EPDM	SAMPLE VLV ZS ASSY, 1.00 X .250, TC X HB, 11 PG A 316L/EPDM
S101499	ZSS-TC-HB-08-04	ZSS-W-1-419-.5-X40-EPDM	SAMPLE VLV ZS ASSY, 1.00 X .500, TC X HB, 11 PG A 316L/EPDM
S100848	ZSS-TC-HB-12-02	ZSS-W-1.5-419-.25-X41-EPDM	SAMPLE VLV ZS ASSY, 1.50 X .250, TC X HB, 11 PG A 316L/EPDM
S101500	ZSS-TC-HB-12-04	ZSS-W-1.5-419-.5-X40-EPDM	SAMPLE VLV ZS ASSY, 1.50 X .500, TC X HB, 11 PG A 316L/EPDM
S100849	ZSS-TC-HB-16-02	ZSS-W-2-419-.25-X41-EPDM	SAMPLE VLV ZS ASSY, 2.00 X .250, TC X HB, 11 PG A 316L/EPDM
S101545	ZSS-TC-TC-04-04	ZSS-W-.5-419-.5-X19-EPDM	SAMPLE VLV ZS ASSY, .500 X .500, TC X TC, 11 PG A 316L/EPDM

## Toggle Sample Valve

PFCA Part Number	Old Figure Number	New Figure Number	Description
S100852	TSV-TC-HB-04-04	SV-TSH-W-.5-419-.5-X40-EPDM	SAMPLE VLV TOG ASSY, .500 X .500, TC X HB, 11 PG A 316L/EPDM
S100850	TSV-TC-HB-04-02	SV-TSH-W-.5-419-.25-X41-EPDM	SAMPLE VLV TOG ASSY, .500 X .250, TC X HB, 11 PG A 316L/EPDM
S100851	TSV-TC-HB-04-03	SV-TSH-W-.5-419-.38-X41-EPDM	SAMPLE VLV TOG ASSY, .500 X .375, TC X HB, 11 PG A 316L/EPDM

## Angle Bleed Valve

PFCA Part Number	Old Figure Number	Elogia Figure Number	Description
S100819	ABV-BL-HB-BL-02	OBSOLETE	BLEED VLV ANGL ASSY, BL X .250, BL X HB 11 PG A 316L/EPDM
S100821	ABV-TC-HB-04-04	OBSOLETE	BLEED VLV ANGL ASSY, .500 X .500, TC X HB, 11 PG A 316L/EPDM
S100815	ABV-TC-HB-04-02	OBSOLETE	BLEED VLV ANGL ASSY, .500 X .250, TC X HB, 11 PG A 316L/EPDM
S101758	ABV-TC-HB-04-03	OBSOLETE	BLEED VLV ANGL ASSY, .500 X .375, TC X HB, 11 PG A 316L/EPDM
S100820	ABV-TC-TC-04-02	OBSOLETE	BLEED VLV ANGL ASSY, .500 X .250, TC X TC, 11 PG A 316L/EPDM
S100816	ABV-TC-HB-12-02	OBSOLETE	BLEED VLV ANGL ASSY, 1.50 X .250, TC X HB, 11 PG A 316L/EPDM
S101759	ABV-TC-HB-12-03	OBSOLETE	BLEED VLV ANGL ASSY, 1.50 X .375, TC X HB, 11 PG A 316L/EPDM
S100817	ABV-TC-HB-16-02	OBSOLETE	BLEED VLV ANGL ASSY, 2.00 X .250, TC X HB, 11 PG A 316L/EPDM
S100818	ABV-TC-HB-24-02	OBSOLETE	BLEED VLV ANGL ASSY, 3.00 X .250, TC X HB, 11 PG A 316L/EPDM
S102362	-	OBSOLETE	BLEED VLV ANGL ASSY, .500 X .250 X .250, TC X HB X HB, 11 PG A 316L/EPDM



ITT Engineered Valves  
33 Centerville Road  
Lancaster, PA 17603, USA  
Tel: +1 (717) 509-2200

**Cam-Line, Cam-Tite, Dia-Flo,  
EnviZion, Pure-Flo, Skotch**

[www.itt.com](http://www.itt.com)

ITT Engineered Valves  
1110 Bankhead Avenue  
Amory, MS 38821, USA  
Tel: +1 (662) 256-7185

**Fabri-Valve**

ITT Bornemann GmbH  
31683 Obernkirchen  
Germany  
Tel: +49 5724 390-0

**EnviZion, Pure-Flo**